

PHILIPS

Service
Manual

Philips EP

800 series
1200 series
2200 series
2500 series
3200 series
3500 series



Contents

General information **3**

Technical information
Maintenance products
Production date (or serial number)
Optional (accessories)
Overview

Technical information **8**

Water circuit
Electric circuit
Coffee and machine specifications
Specific tools and equipment
Specification for the measurement of the coffee products temperature
Specification for the measurement of the Milk products temperature.
How to check connectivity board (Only for Wi-Fi models)
Operating logic
Brew Unit maintenance - where to grease and positions

Disassembly- and Reassembly advice **22**

Test mode **30**

Functions/features explanation **40**

Steam out
Descaling
Temporary solutions
Espresso Philips Service Center (EPSC)
Deactivate AquaClean filter reminder
Deactivate the beeping sound of the buttons
Reset drinks settings to default setting
Repair Flow

Version history **48**

Important repair instructions

- Only skilled personnel should carry out the repair.
- After repair the appliance should function properly.
- After repair the appliance has to meet the regulatory- and safety requirements that were applicable at the time of release of the model.
- After repair the appliance always has to be tested for electrical safety according VDE 0701-0702 and for medical products IEC 62353.

Philips EP Series

General information



Technical information

- Voltage : 220 - 240 V
- Frequency : 50 - 60 Hz
- Power consumption : 1450 W
- Standby power consumption: 0.22 W
- Auto shut-off time : 15 min
- Capacity water tank : 1.8 litres removable
- Capacity coffee bean : 275 g
- Capacity LatteGo : 250 ml
- Capacity Coffee grounds : 12 pucks
- Cord length : 1 m
- Pump pressure : 15 bar
- Adjustable spout height : 85 - 145 mm
- Weight and dimensions:
 - Weight of product : 7 - 7.5 kg
 - Dimensions of product : 246 x 372 x 433 mm (WxDxH)

Maintenance products

- Descaler 996530067222
- Jar of Grease 1Kg 421945054671
- Jar of Grease 250g 421945054681
- Silicone grease 996530045784

Production date (or serial number)

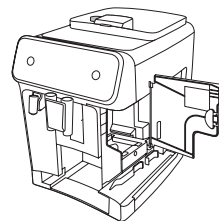

Optional (accessories)

- AquaClean water filter CA6903
- Descaling solution CA6700
- Brew group grease HD5061
- Coffee oil remover tablets CA6704

General information

Overview

CMF (classic milk frother)



Latte Go



General information

Overview

CMF (classic milk frother) 800 series



CMF



General information

CMF



Latte Go



General information

CMF (Only for Wi-Fi models)



Latte Go (Only for Wi-Fi models)



Latte Go (Iced coffee version)



Technical information

Water circuit

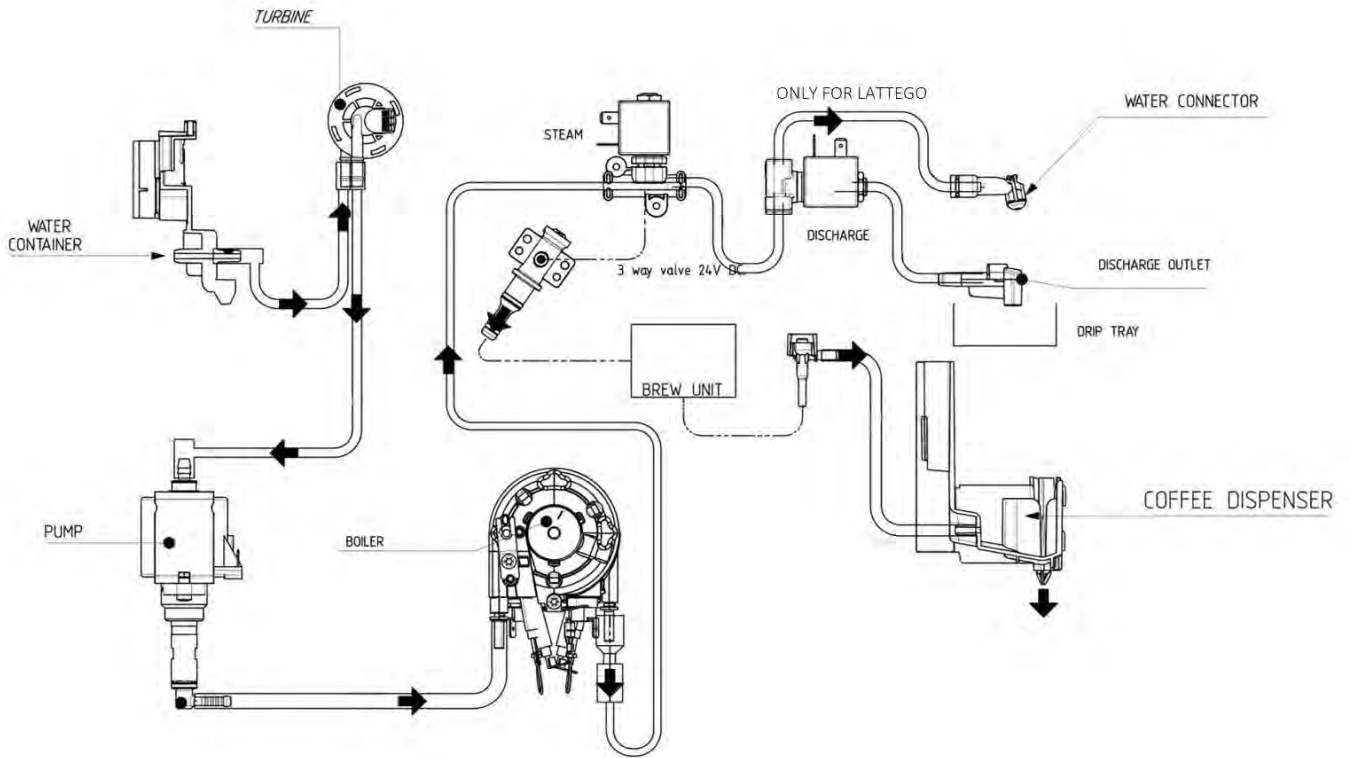

Electric circuit

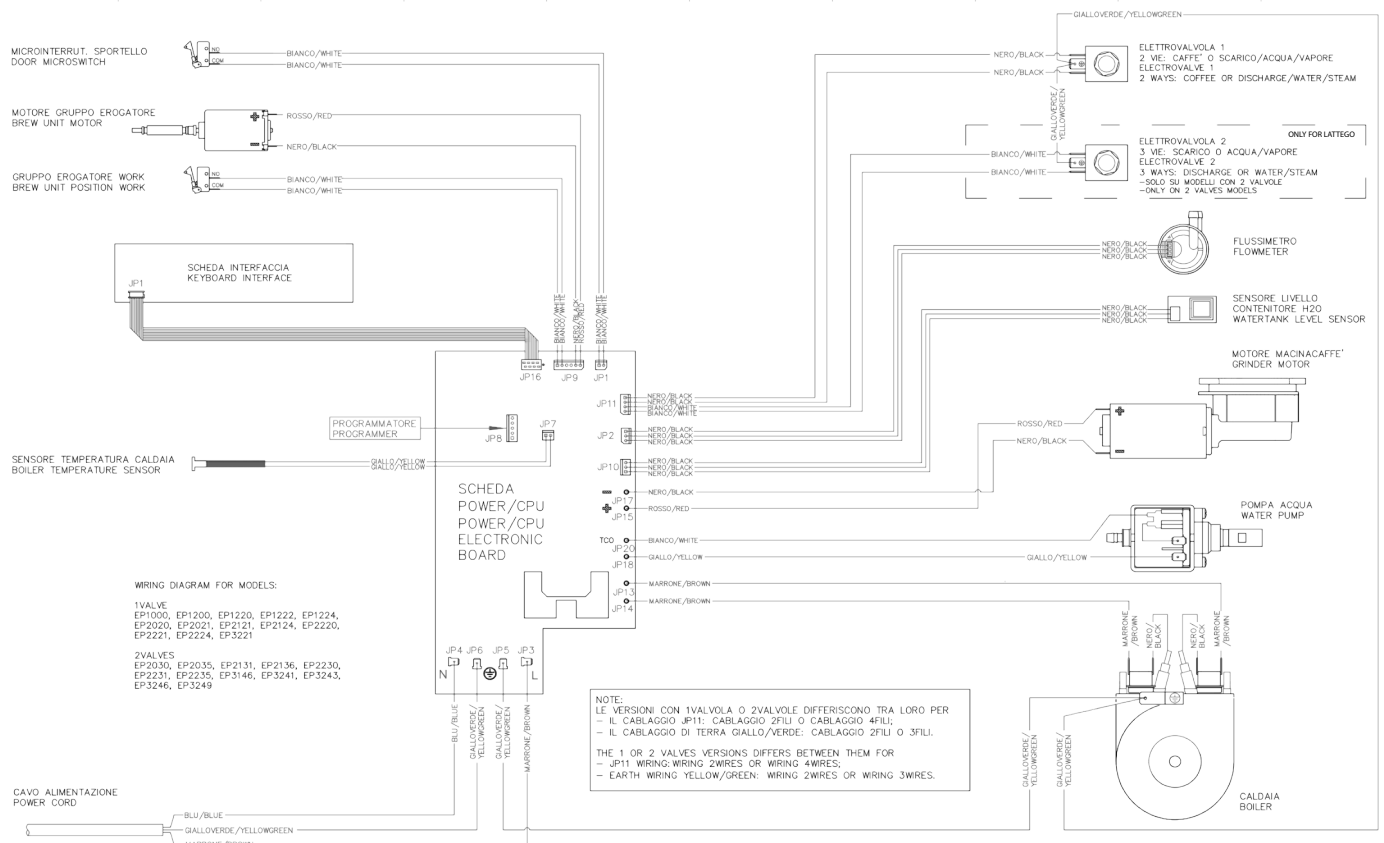

Technical information

Coffee and machine specifications

Drinks	Low button (ml)	Medium button (ml)	High button (ml)	Volume adjustment (only at high button - ml)
Espresso	30	40	70	40-220
Coffee	100	120	200	120-220
Espresso lungo	60	80	180	80-220
Americano (water)	40 (50)	40 (110)	40 (160)	40 (110-360)
Cappuccino (milk)	30 (90)	40 (120)	60 (200)	40-220 (120-340)
Latte macchiato (milk)	30 (120)	40 (200)	50 (340)	40-220 (200-340)
Hot water	60	150	360	150-360
Iced coffee	90	120	150	120-220

Coffee grounds drawer		Description and values
Time-out for coffee grounds drawer		5 seconds
Reset dreg counter		Dreg emptying alarm, if the coffee grounds drawer is removed for more than 5 seconds.
STANDBY		Description and values
Time (default)		15 minutes
Time programmed by Consumer/Service		NO
Boiler temperature during Standby		Boiler OFF
WATER TANK		Description and values
Water reserve (pulses) with water filter		125 ml (260 pulses)
Water reserve (pulses) with no water filter		125 ml (260 pulses)
Water reserve modifiable by Production/Service departments		NO
"Fill tank" alarm		YES
Connect to water mains		NO

Specific tools and equipment

Description	Notes
Flathead screwdriver	# 0, # 2
Torx screwdriver	(T10)
Pliers for Oetiker clamps	
Digital Thermometer	Type K (accuracy for temperature of 0,05 % or $\pm 0,3^{\circ}\text{C}$)
Temperature probe	80PK-22 (80AK-A Thermocouple adapter required)
Scale	KERN EMB 500-1 or comparable device with a base accuracy of 0,05 % or $\pm 0,5 \text{ g}$
Power meter	Voltcraft EnergyCheck 3000 or comparable device with a base accuracy of 1 % or $\pm 5 \text{ W}$
Stopwatch	Basic model
Serkit	Tool needed for programming with our service tool
EP series cable	Cable for Philips EP1200-2200-3200 series
EPSC (Espresso Philips Service Center)	Tool used to flash the SW on the machines (for SW upgrade and diagnostics mode). Refer to SDA_114585

Technical information

Specification for the measurement of the coffee products temperature

Before measuring the in-cup temperature make sure the following conditions will be met:

Conditions:

- Water temperature in tank: 23°C (+/-2°C).
- Use a plastic cup (see picture 1).
- Use a digital thermometer (see picture 2) (e.g. type K probe diameter max 2mm (see picture 3)).
- The coffee machine is tested without any change of parameters or calibrations, which may affect the temperature of products, so the measurement of temperature must be done with machine in default factory setting.

Procedure:

- Place the plastic cup under the dispensing spout. (picture 1)
- Dispense coffee
- Measure the temperature immediately after coffee has being dispensed, you need to finish the measurement within 12 seconds. The temperature in the cup is measured by placing the probe of the thermometer in the cup near the bottom. Then stir the probe in the cup for 5 to 6 times and read out the thermometer values during stirring. Hold the probe still in the center of the cup.
- Record the highest value.

Depending on the coffee volume selected to measure, you would need to position the probe on several height levels to measure the correct temperature in the plastic cup.

10mm for 35gr - 17mm for 60gr - 35mm for 120gr (see Picture 3).

Espresso Coffee Italy Q.ty 40 gr.

Temperature of 1st product 69°C ≤ 85°C

Temperature of 2nd product 72°C ≤ 85°C

Coffee Q.ty 120 gr.

Temperature of 1st product 72°C ≤ 85°C

Iced coffee Q.ty 120gr.

Temperature of 1st product 54°C ≤ 64 °C

Temperature of 2nd product 54°C ≤ 64 °C

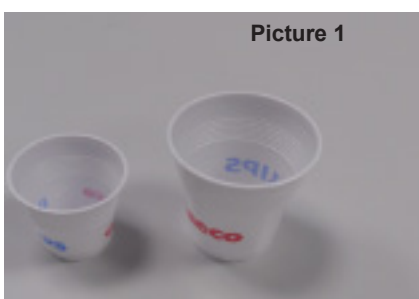

Picture 1



Picture 2

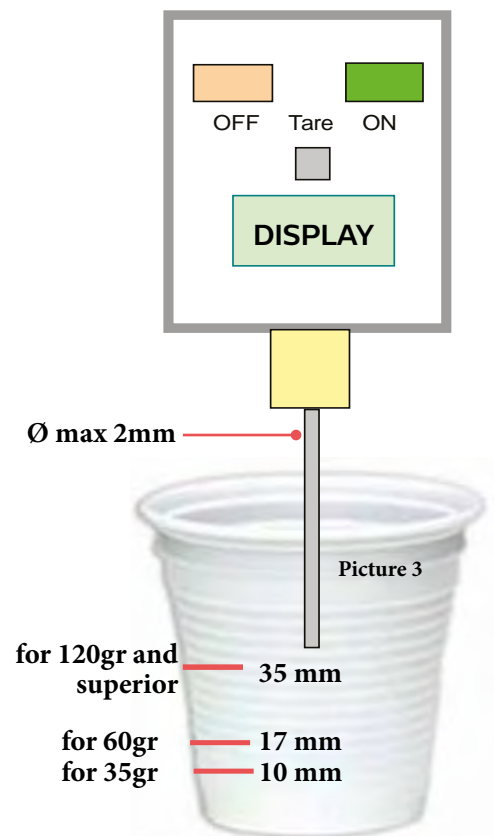

Picture 3

Philips EP Series

Technical information

Specification for the measurement of the Milk products temperature.

Before measuring the milk froth temperature and milk froth height make sure the following conditions will be met:

Conditions:

- Use semi skimmed UHT milk with a fat percentage between 1.5 – 1.8%
- Milk is cooled between 4 – 8°C (refrigerator temperature).
- Use a plastic transparent measuring beaker which can hold min 250mL with an inner diameter of 70mm.
- Use a digital thermometer (see picture 2, page 8) (e.g. type K probe diameter max 2mm (see picture 3, page 8)).

Depending on the frothing system, the applicable specification need to be selected to determine if the appliance is within specification.

Available systems:

- Manual system pannarello (CMF)
 - Temperature specification: $\Delta \geq 45^{\circ}\text{C}$
 - Froth height specification: $\geq 15\text{mm}$ on 100gr. of brewed milk product
- Automatic system (Latte Go)
 - Temperature specification: $\Delta \geq 60^{\circ}\text{C}$
 - Froth height specification: $\geq 15\text{mm}$ on 100gr. of brewed milk product

Milk temperature in the beaker:

- System with CMF: With milk at Trefr. (about 4-10 °C): $\Delta \geq 45$
- System with LatteGo: With milk at Trefr. (about 4-8 °C): $\Delta \geq 60$

How does it work:

- The milk is heated in the first chamber of the carafe thanks to the steam.
- Then, it is mixed with air and frothed in the middle chamber.
- Finally, in the outlet chamber, the 'typhoon effect' perfects the milk texture by removing the large bubbles



Technical information

Procedure to measure the temperature of the milk.

1. Place the beaker under the milk spout.
2. Dispense 100gr of milk froth.
3. Measure the temperature immediately after milk froth is dispensed, you need to finish the measurement within 5 seconds.
4. The temperature is measured by placing the probe of the thermometer $\pm 10\text{mm}$ above the bottom of the beaker.
5. Then stir the probe for 3 to 5 times and read out the thermometer values during stirring, values should stabilize.
6. Hold the probe still in the center of the beaker and read out the temperature.

Technical information

Procedure to measure the milk froth height.

Manual system (CMF)

Pour 100cc. of milk at Trefr. in a beaker of 250 ml of capacity and with a inner diameter of 70 mm; with machine in steam mode:

1. Place the beaker with the frother dipped in milk, dispensing steam and start the chronometer.
2. After about 30 to 60 seconds, stop the steam and check the result on milk.

Automatic system (Latte Go)

After setting the machine to delivery of 120gr. of product:

1. Launch the “hot milk” function.
2. Collect the product in a beaker with a 250ml of capacity and with an inner diameter of 70 mm, and verify the result obtained on milk. Carry out the test using milk at a Trefr..

In case the machine allows modify of the emulsion through the menu, use the machine with the emulsion set to the default value.

Related to the above testing procedure derives the following table of acceptability:

Grams of product	Minimun height of the milk cream
≥ 130	≥ 30mm
120	≥ 25mm
110	≥ 22mm
100	≥ 20mm
90	≥ 16mm
80	≥ 13mm
70	≥ 11mm

To verify the height of the cream, a practical example is to add to dispensed product a small amount of coffee. The addition of coffee immediately highlights the surface of separation between liquid and cream.

For Pannarello models only:

In case the consumer is complaining due to a poor milk quality check the status of the Pannarello internal tube. If the internal tube was pushed internally up the pannarello proceed with the replacement of the pannarello.

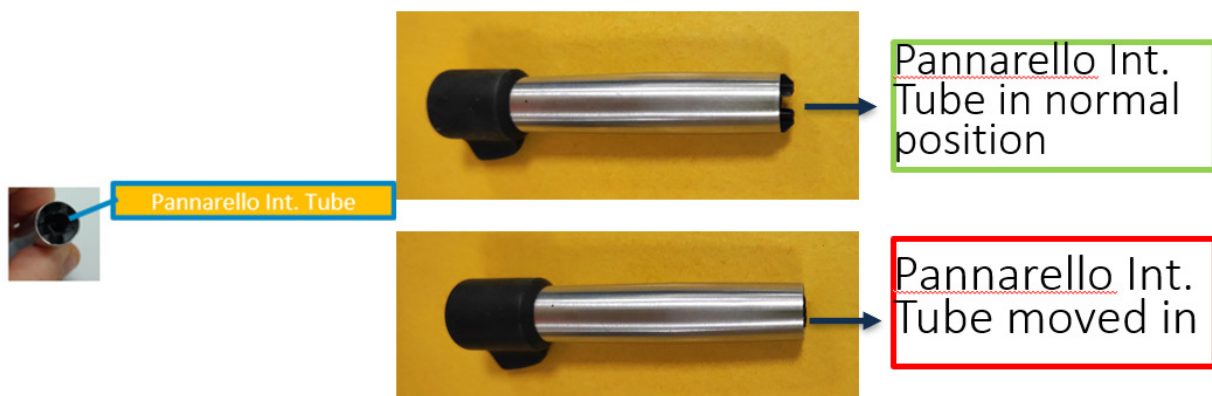

Technical information

How to check connectivity board (Only for Wi-Fi models).

Connecting to Wi-Fi



For a connected experience, you have to connect your coffee machine to your Wi-Fi network with the free Coffee + app. You can download the free Coffee + app* for iOS® or Android™ from the App Store or from Google Play. Follow the instructions in the app to connect your coffee machine to your Wi-Fi and to pair your coffee machine with the Coffee + app. In this user manual you can find step-by-step instructions for setting up the Wi-Fi connection (see ‘Setting up the Wi-Fi connection for the first time’).

*The app may not be available in your country.

Wi-Fi connection

Setting up the Wi-Fi connection for the first time

Connect your coffee machine to a 2.4 GHz 802.11 b/g/n home Wi-Fi network.

Connecting your coffee machine to your home Wi-Fi network, provides you with an enhanced user experience.

1. Make sure that you have the password of your Wi-Fi network at hand before you start the Wi-Fi set-up process and that your smartphone or tablet, the coffee machine and the Wi-Fi router are within range of each other.
2. Download the Coffee + app on your smartphone or tablet from the App Store or from Google Play.
3. Fill the water tank of your coffee machine with fresh water and place it back into the machine.
4. Make sure that when you start the Wi-Fi set-up process, your smartphone or tablet is connected to the same Wi-Fi network that you want to connect your machine to.
5. Follow the instructions in the app to pair your smartphone or tablet with the coffee machine and connect your coffee machine to your Wi-Fi.
6. When the Wi-Fi light on the user interface of the coffee machine lights up continuously, and the app shows that the machine is connected, the Wi-Fi connection has been successfully established.
 - You can check if Wi-Fi installation has been established successfully by checking the connection status in the app and by switching the machine on and off in the app. If the Wi-Fi light stays off or keeps flashing, you can check the troubleshooting section in this booklet to find a solution.

You are now ready to start your connected experience.

If the network has changed and the connection needs to be re-established, perform the setup again (see ‘Changing the Wi-Fi connection’).

This app supports the latest versions of Android™ and iOS®. Please check the App Store or Google Play for the latest update of supported operating systems and devices.

The Wi-Fi setup process can be cancelled in the app or by exiting the app.

To be able to switch your coffee machine on and off with the app, the smartphone or tablet with the app must be connected to the same Wi-Fi network as your coffee machine.

Technical information

Connecting your smartphone or tablet to the machine that is already connected to the Wi-Fi

When the first user has connected the coffee machine to the Wi-Fi network, all other users don't have to perform the whole Wi-Fi setup process again. They can simply connect a smartphone or tablet to the machine by finding the machine in the Coffee + app and pairing with it.

1. Make sure the smartphone or tablet is connected to the same Wi-Fi network as the machine.
2. Download the Coffee + app on the smartphone or tablet from the App Store or from Google Play.
3. Follow the instructions in the app to pair the smartphone or tablet with the coffee machine.

Switching the Wi-Fi connection of the machine on and off

Switching the Wi-Fi connection off

If the Wi-Fi connection is on and you want to turn it off, you can follow the steps below.

1. Switch on the machine and wait until the machine is ready for use.
2. Press and hold the start/stop button until the Wi-Fi light starts flashing several times and then goes off.

Switching the Wi-Fi connection back on

When you have switched off the Wi-Fi connection and you want to switch it on again, you can follow the steps below.

1. Switch on the machine and wait until the machine is ready for use.
2. Press and hold the the start/stop button until the Wi-Fi light starts flashing several times and then lights up continuously. The machine will reconnect to the Wi-Fi network it was previously connected to.

Changing the Wi-Fi connection

Change the Wi-Fi connection when the network to which your machine is currently connected has changed or if you wish to connect the machine to a different/new network.

If one of the users changes the Wi-Fi connection, every other user only needs to connect the smartphone or tablet to that same Wi-Fi network to be able to control the machine with the app again.

You can change the Wi-Fi connection by following the steps below.

1. Switch off the machine.
2. Press and hold the hot water icon (for type EP2520) or the cappuccino icon (for type EP3546), until the start/stop button starts flashing.
3. Press the start/stop button to confirm that you want to delete the current Wi-Fi connection.
4. Navigate in the app to machine settings and remove the machine from the app.
5. Follow the steps in the app to set up the Wi-Fi connection.

The instruction above only explains how to connect the machine to a new network or to reconnect the machine to its current network if the network name or password has been changed.

Technical information

Resetting all network settings and connections

If you follow the instructions in this section, all smartphones and tablets and your Alexa device will no longer be connected to the coffee machine. The factory settings will be restored and all personalized settings will be erased.

1. Switch off the machine.
2. Press and hold the espresso icon until the start/stop button starts flashing.
3. Press the start/stop button.
4. Navigate in the app to machine settings and remove the machine from the app.

When you want to reconnect to the Wi-Fi network, follow the steps in the app to setup the Wi-Fi connection again.

After a reset, it can take at least five minutes before the machine is able to perform the Wi-Fi set up again.

Note:

For wi-fi models only: Please note the update of the software is not possible via EPSC. It can be done with wi-fi connection.

Technical information

Operating logic

Switching on

When the machine is switched on, the gear motor repositions itself as follows:

- It acts on microswitch 1
- The gear motor changes its rotation direction and moves upwards again by approx. 1-2 mm.
- The boiler begins to heat the water for approx. 45 sec, in order to reach the optimal temperature (established by the software).

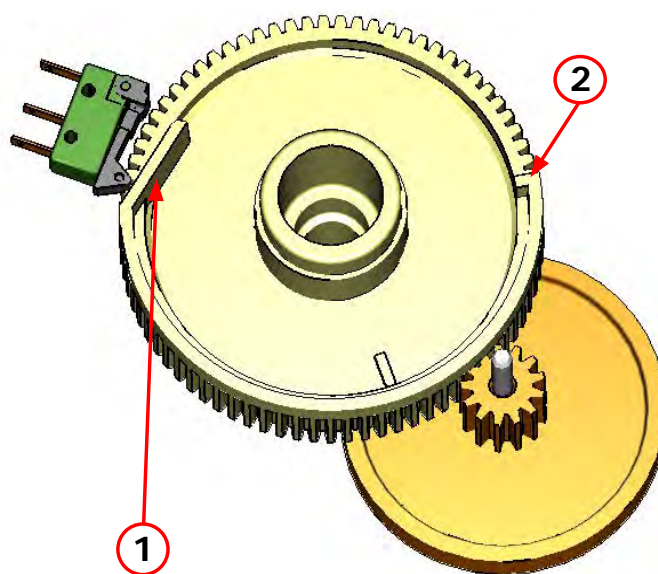

The gear motor is powered by a direct current motor that engages with the smaller double toothed wheel using a worm screw. The unit is mounted on the axle of the large gear wheel and when a coffee is requested, it moves from the standby position to the dispensing position, and then back to the standby position again. The microswitch indicates to the gear motor when the brew group is in the work position or home position.

- Standby position: 1
- Dispensing position: 2

Temperature sensor (adjustment)

Temp. (°C)	R nom (kΩ)	ΔR (+/- %)
20	61.465	4.0
50	17.617	3.1
75	7.214	2.4
80	6.121	2.3
85	5.213	2.2
90	4.459	2.1
100	3.3	1.8
125	1.653	2.4
150	0.893	2.8

An NTC is used as a temperature sensor; in the event of overheating this reduces boiler element power consumption. The electronic system detects the current boiler temperature from the drop in voltage of the sensor and adjusts it accordingly. Heating element values and corresponding temperatures: see table.

Technical information

Coffee grinder

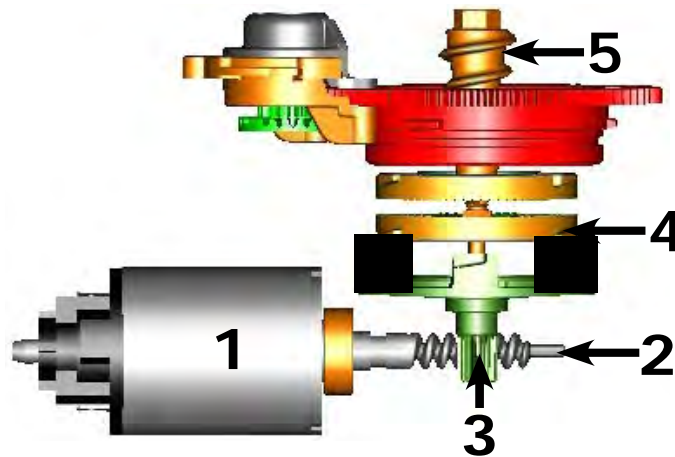

The coffee grinder is driven by a direct current motor (1) using a worm screw helical wheel transmission (2). The worm screw (2) drives a plastic gear wheel (3), which turns the lower grinder (4) and the increment pin (5)

Coffee grinder blocked

When the coffee grinder is working, the software monitors the current consumption. If the current value is very high, the machine concludes that the coffee grinder is blocked; instead, if the current value is in the middle, the machine concludes that all is ok and it goes on to do the product.

Because the current consumption of grinder changes depending on the situations (motor new or old, cold or hot, coffee blends, etc.), these current targets are not static, but dynamic.

Technical information

Milk container

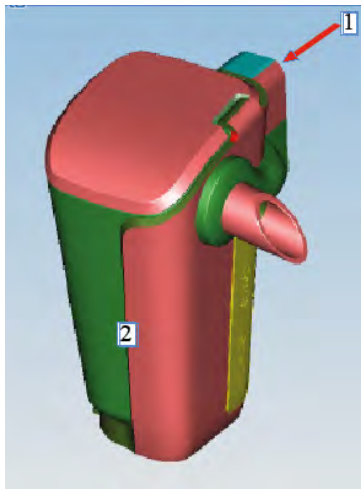

- 1) Steam inlet
- 2) Complete LatteGo milk container assy

Steam flows into the LatteGo



Air, steam and milk are mixed at high speed resulting in a dense silky smooth milk foam

The two LatteGo parts clicked together create a channel in which steam pressure sucks up milk through the hole at the bottom of the container

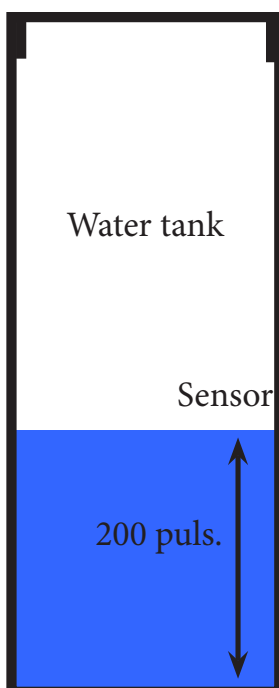

“Water low” message (water reserve)

Function:

The water level is monitored by a capacitive sensor, located one third of the way up the water tank wall.

If the electronics assembly detects, by means of the sensor, that the amount of water in the tank has dropped below the above mentioned level, a water reserve remains available for the dispensing process underway (this will cover 200 flow meter pulses).

The product dispensing process will then come to an end.

If a dispensing cycle ends after the sensor has been triggered (in the reserve) then the display “Water low” continues to be displayed during the following dispensing cycle.

Technical information

AquaClean water filter

The AquaClean filter is designed to reduce limescale deposits in the coffee machine and provide filtered water to preserve the aroma and flavor of each cup of coffee. By using a series of 8 AquaClean filters, there is no need to descale the machine for 5000 cups (It depends both on the type of coffee used, rinsing and cleaning programs).

We recommend installing the water filter AquaClean the first use of the machine to the maximum before using 5 L of water. The machine display will indicate when the filter needs to be replaced. The maximum limit is equivalent to 110 L of water.

The conditions related to the filter work environment (water, therefore, an active environment for bacteria and microorganisms), require the replacement with a minimum frequency (we suggest 3 months from the activation to ensure the best performance). The filter starts working from the time it is filled with water and continues working even with the machine off. It cannot be deactivated manually, as it must end its life cycle.

At the filter activation the display shows the icon with the percentage of use:

- Initially 100% then decreasing.

When the autonomy of the current filter becomes less than 8 L of water the display shows:

- The icon flashing slowly. It means 10%.

When the autonomy of the current filter becomes less than 2 L of water the display shows

- The icon flashing quickly. It means 0%.

After a maximum of 110 L of water supplied the flashing light turns off and the machine needs to be descaled.



Descaling request

Descaling frequency in AQUACLEAN					
The first activation must make before you've paid up to 5000ml products because mind thinks as if he had the filter					
Hardness	Filter number	Percentual on display 10% the icon flashes slowly. (encourage the consumer to buy the filter)	Percentual on display 0% the icon flashes quickly. (tell the consumer to change the filter)	MAX Quantity water, the icon turns off. (replace filter)	
Indifferent	From 1/8 to 7/8	8050ml	2000ml	110000ml	Replace filter (you cannot turn off)
	8/8				Descaling

If after descaling or after the use of a filter this is not reactivated, the machine recognizes the water hardness setting and calculates as in the table below

Descaling cycle frequency			
Hardness	WATER HARDNESS	Without water filter	Not reactivating the filter
1	Soft (up to 7°dH)	240 litres (480,000 pulses)	210 litres (420,000 pulses)
2	Medium (7° - 14°dH)	120 litres (240,000 pulses)	105 litres (210,000 pulses)
3	Hard (15° - 21°dH)	60 litres (120,000 pulses)	52.5 litres (105,000 pulses)
4	Very hard (over 21°dH)	30 litres (60,000 pulses)	26.25 litres (52,500 pulses)

The default water hardness level is 4. Each litre of water corresponds to approximately 2,000 pulses.

Philips EP Series

Technical information

Brew Unit maintenance - where to grease and positions

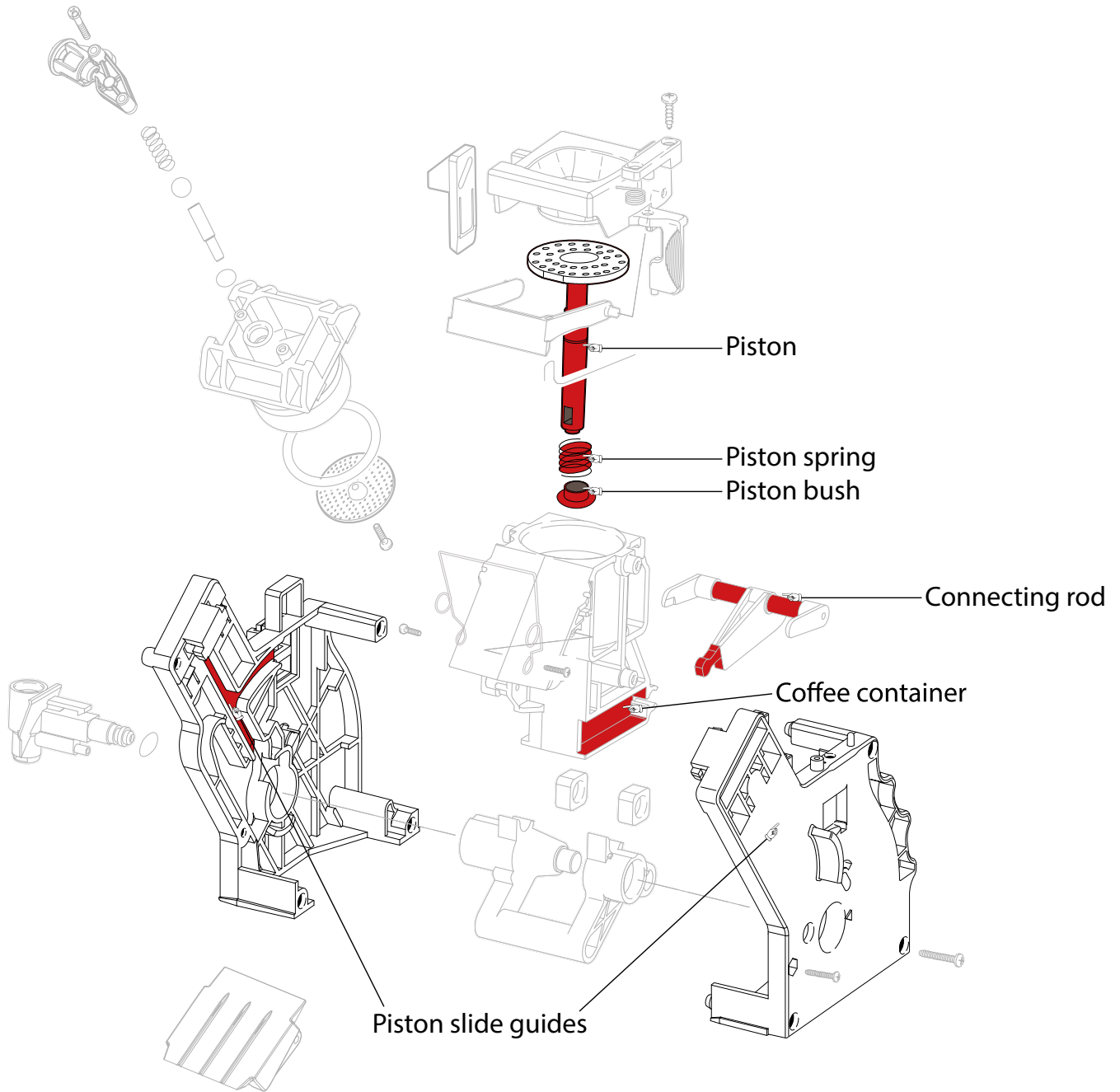

Brew Unit

Home Position

Work Position

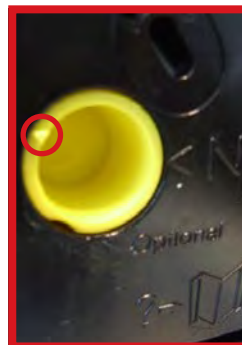
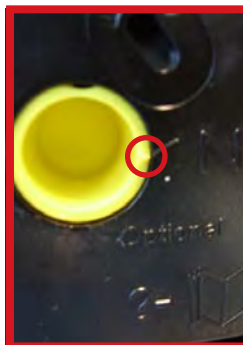

Disassembly - and Reassembly advice

Before you start dismantling!

 *For your safety be sure the plug is disconnected from the mains!*

The product is designed for easy access to the internal components. Make sure that all accessories have been removed.



Removal of the housing:

1. Make sure the power cable is unplugged.
2. Take out the four screws and pull up the upper cover.



Philips EP Series

Disassembly - and Reassembly advice

3. When assembly the finger-protection screw:

- **Up to SN TW901907111749 use torque force 1.2Nm +/- 0.1**
- **From SN TW901907111750 use torque force 0.8Nm +/- 0.1**

4. Take out the two screws in the back panel and remove it.



5. To remove the two laterals panel take out 3 screws for each of them



Disassembly - and Reassembly advice

Removal of the UI

1. To remove the UI push the 2 snaps inside (indicated with the red arrows):

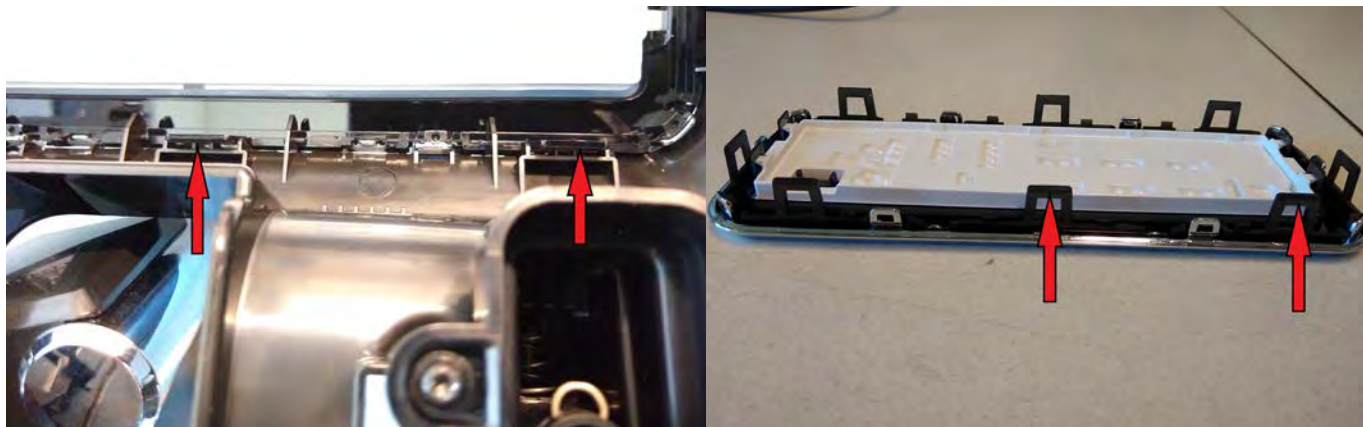

2. Then unplug the cable.

Do not use a screwdriver, but pull it keeping the flat cable and not the connector (some force is required)



3. Click on the 4 snaps to remove the UI board protection.



Disassembly - and Reassembly advice

4. To re-mount the UI start keeping inserted first the upper part of the cover, then push it. Make sure the 4 snaps are properly closed

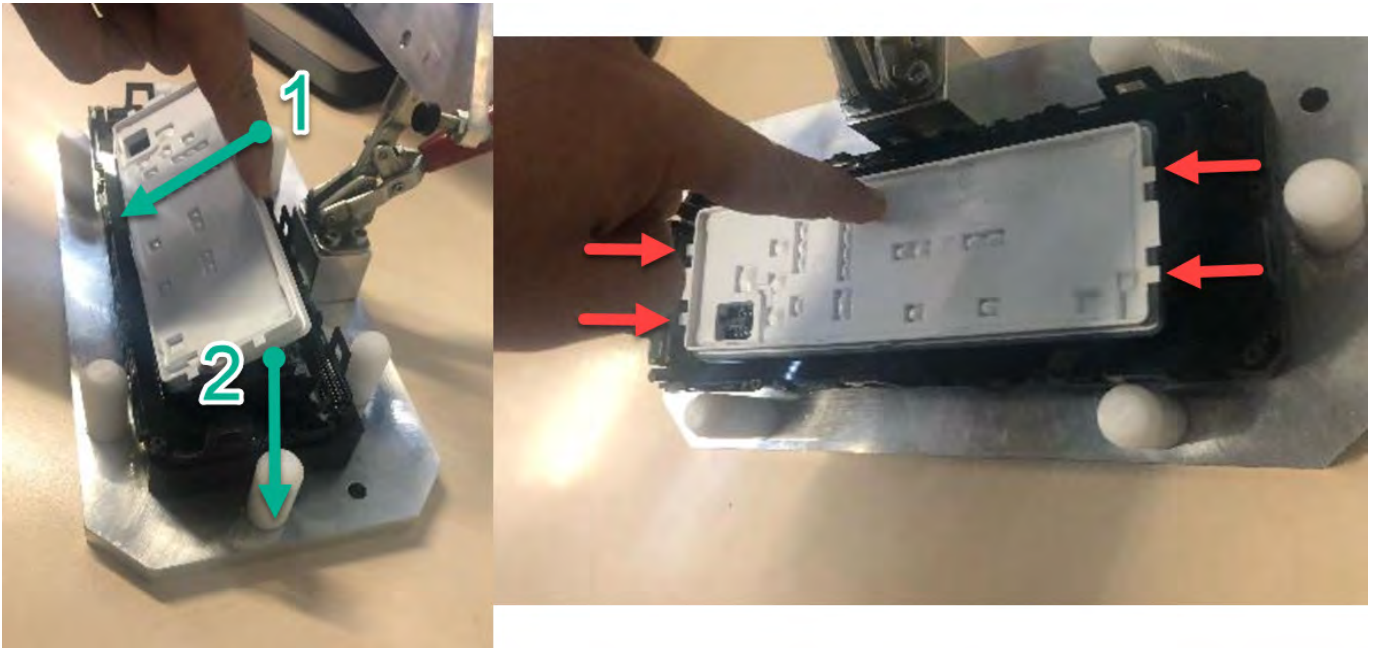

Removal of the Grinder

1. Pull out the grinder assy
2. Remove the electric connections

Removal of the Electrovalves

1. For the upper EV pull outwards the valve holder.
2. For the lateral EV take out the 2 screws, then remove the valve.

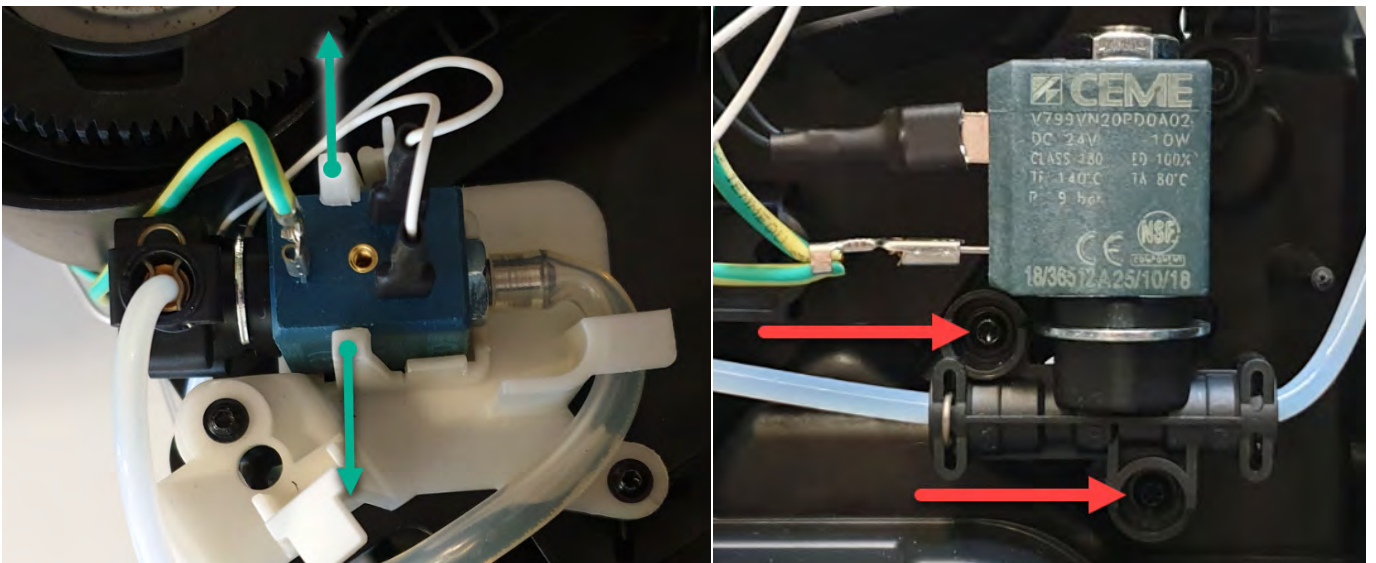

Disassembly - and Reassembly advice

Removal of the Gear motor

1. Take out the brew unit motor cover removing the 2 screws

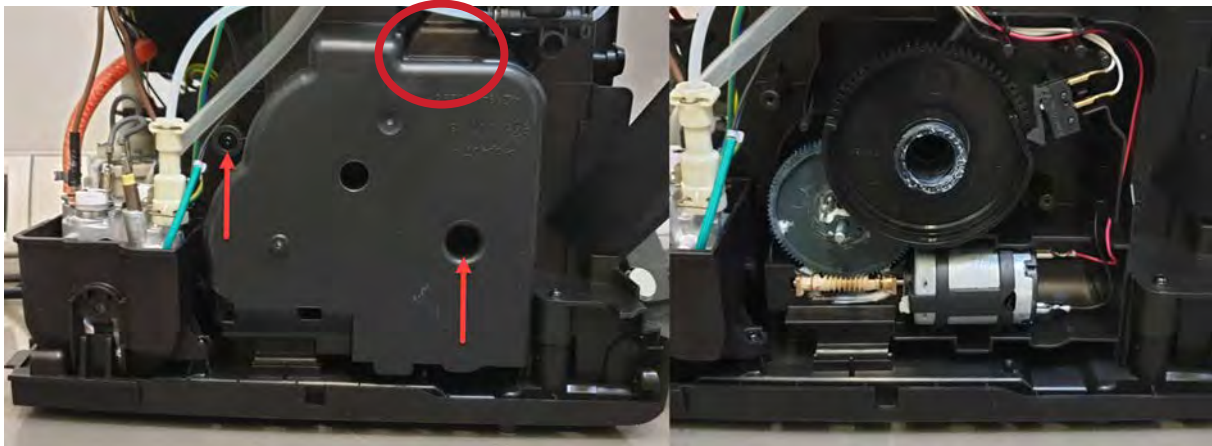

Be aware there is an empty hole (in the red circle). Do not insert any screw inside

Removal of the Boiler

1. Remove all the electrical and water circuit connections
2. Take out the 2 screws from the boiler support.

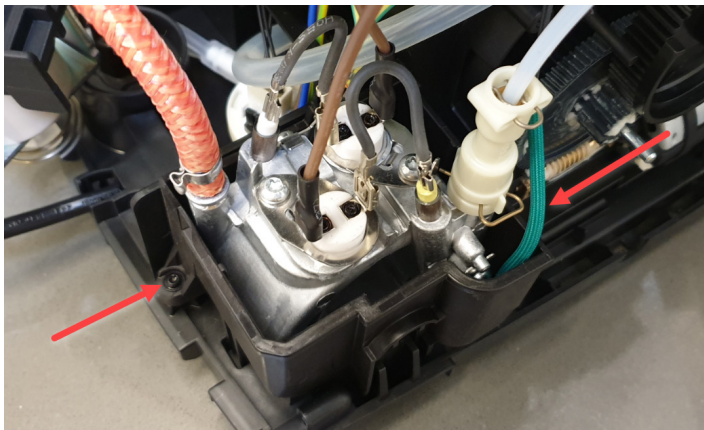

Removal of the Flowmeter

1. Remove the electric connection
2. Press on the holder to pull out the flowmeter, then remove water connections.



Disassembly - and Reassembly advice

Removal of the Mainboard

1. Remove all the electric connections
2. Keep pressing on the left holder to be able to release the board.

The mainboard contains several fixed wires which cannot be disconnected from the board.

The UI cable is also fixed to the mainboard.

To completely remove the mainboard from the appliance, disconnect all fixed wires from their destination component.

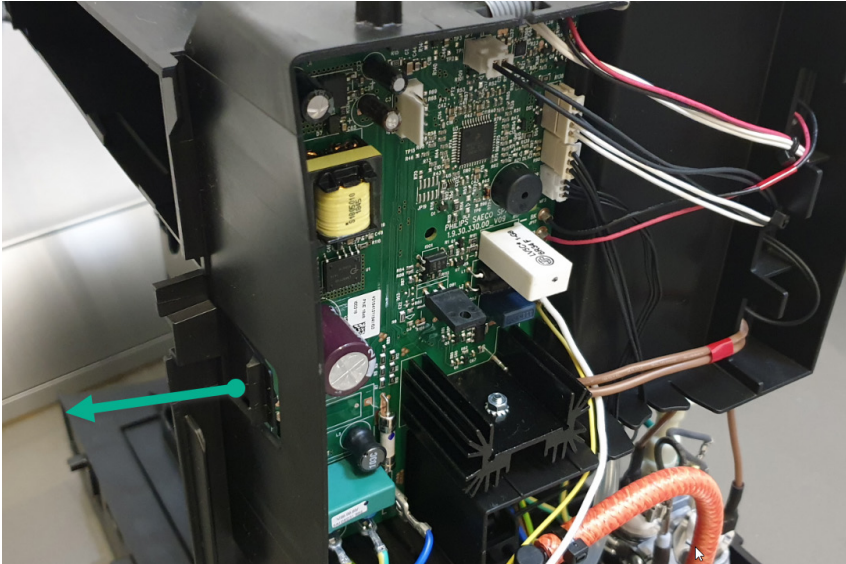

Removal of the Pump

1. Pull the pump holder to the right
2. Remove all the connection

When reassembling the pump, ensure to use hot melt to fix the thermal fuse.



Disassembly - and Reassembly advice

Removal of the Coffee and Water spout

1. To remove the front panel start at the lower snap (1). Push to the left and on top of it, then the cover opens at the front side and you can put a finger (nail) in between. Then push on the upper snap neck (2).
2. Pull down the coffee spout, then remove the pipe.

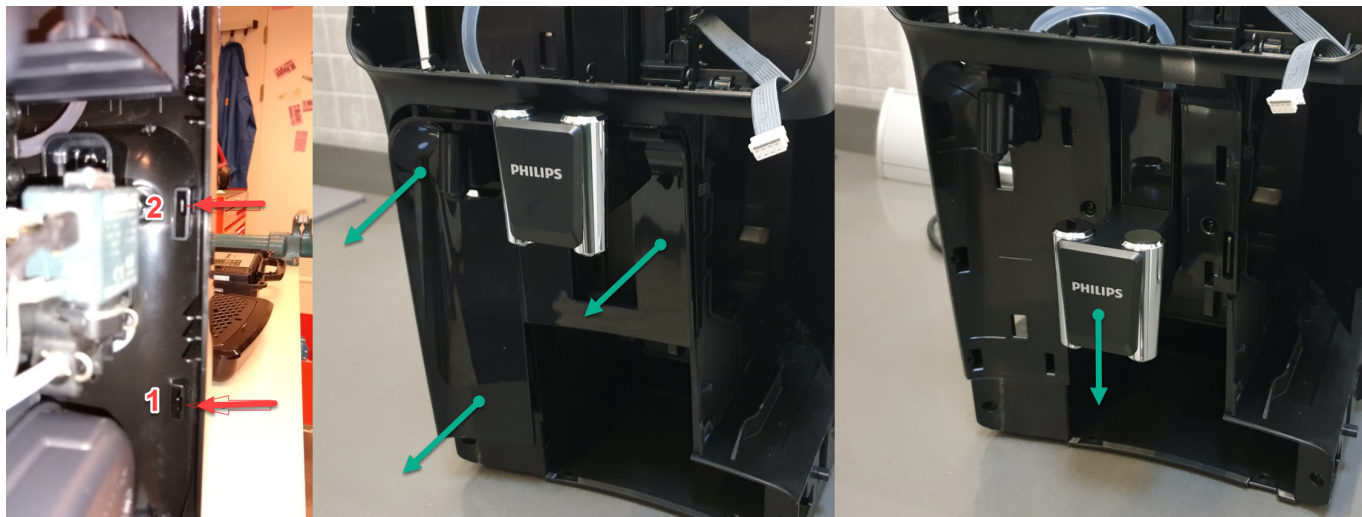

3. Take out the 2 screws
4. Unsnap the click (as shown in picture) and pull the front case cover to remove it (some force is needed).

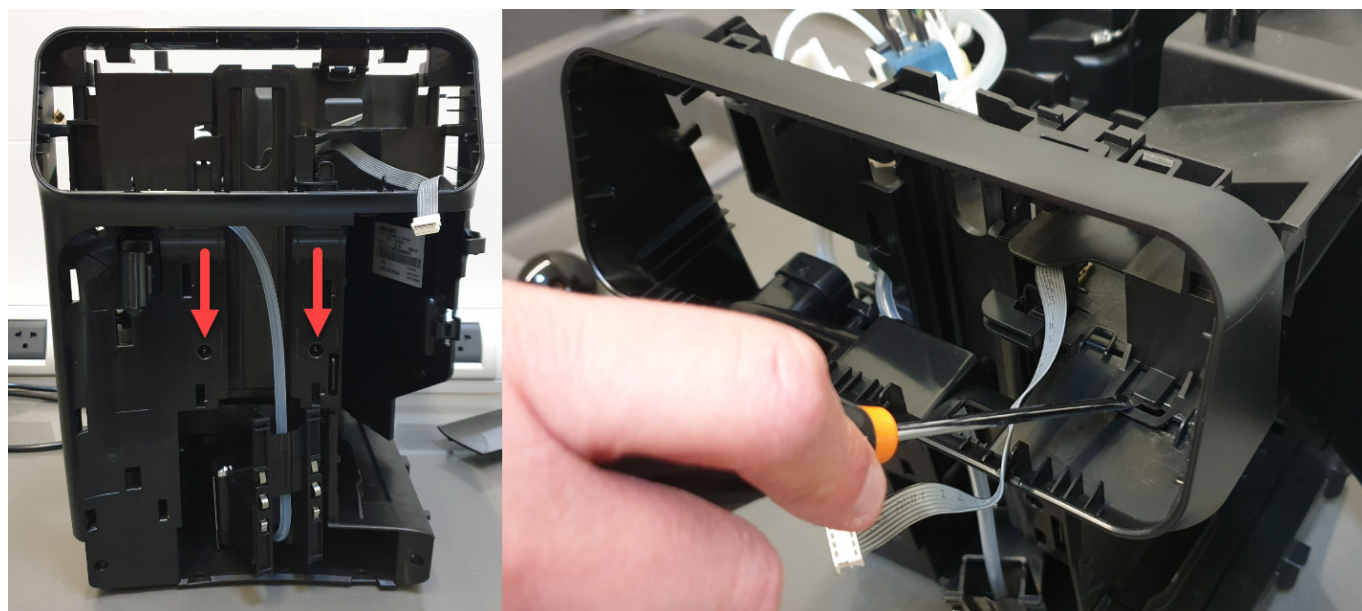

Disassembly - and Reassembly advice

5. Remove the two screws to release the water spout.

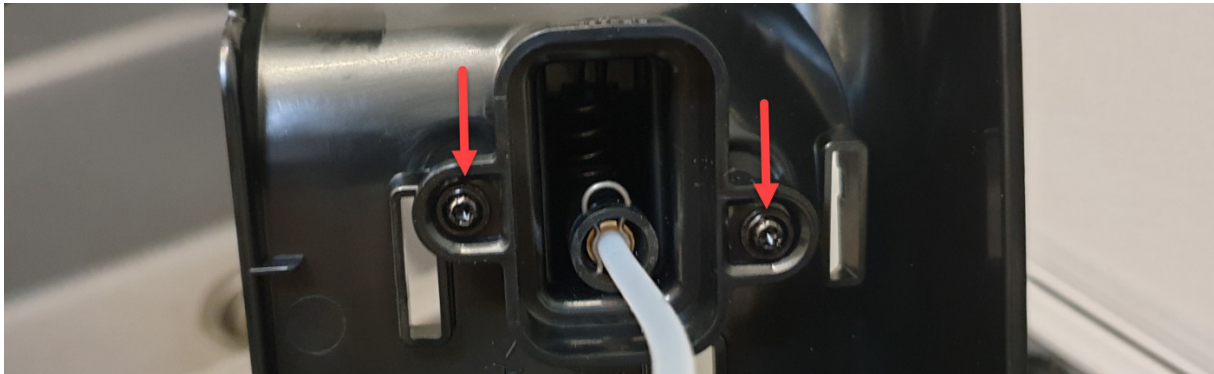

Removal of the Microswitch

1. To remove the microswitch please take extra care, slowly pulling it out from its place, then remove the connections.

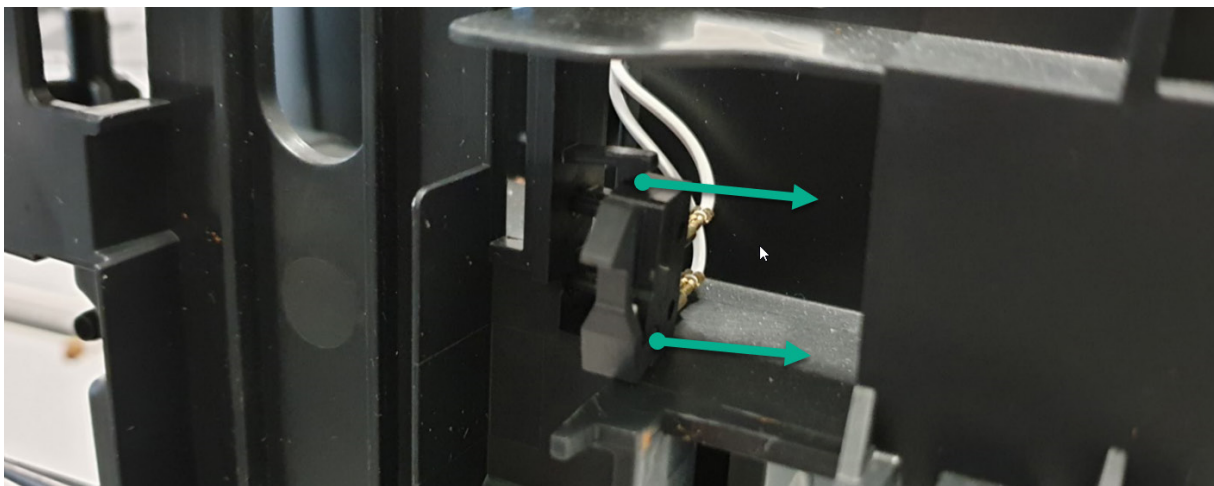

Test mode

Introduction

Test mode is used to test the machine in its mechanics and electronic components

How it works

The machine enters in test mode by pressing in sequence **B5 - B2 - B4 - B3** in the first two seconds after switching on the machine, by connecting the power cable to the mains.

Once entered the machine shows led L1 and L2 flashing in series (Level 0).



Test mode

There are 3 different levels, in each level the coffee-machine can execute different commands,

- **Level 0:** Entry Level; in this level the operator can
 1. execute the Reset of the error log by pressing B3 for 3s (L24-L25-L26 will flash to confirm)
- **Level 1:** In this level the operator can
 1. test all the Buttons and Leds activation and color:
 - a. Buttons : B1, B2, B3, B4, B5, B6, B7, B8, B9, B10, B11, B12, B13.
 - b. Leds :L1(O), L2(O), L3(O), L4(O), L5(O), L6(O), L7(O), L8(O), L9(O), L10(O), L11(O), L12(O), L13(O), L14(O), L15(O), L16(O), L17(O), L18(O), L19(B), L20(O), L21(O), L22(O), L23(O), L24(R), L25(R), L26(R), L27(O)
 2. Check the buzzer sound.
- **Level 2:** In this level the operator can:
 1. Test all the loads:
 - a. Move the Brew Unit upward and downward.
 - b. Open/Closed the EVs.
 - c. Start the Pump.
 - d. Start the Heater
 - e. Start the Grinder
 2. Test all the sensors:
 - a. Microswitch door activated/not activated.
 - b. Microswitch BU position (work/home) activated/not activated.
 - c. Hall sensor water level activated/not activated.
 - d. Flowmeter
 - e. NTC

The user can switch the level by pressing the Button B1, while pushing the button the machine shows the level of the test:

- a) Level 1 : Led L1 ON (O),
- b) Level 2 : Led L1 ON (O), Led L2 ON (O)

Legend:
(O) = Orange
(B) = Blu
(R) = Red

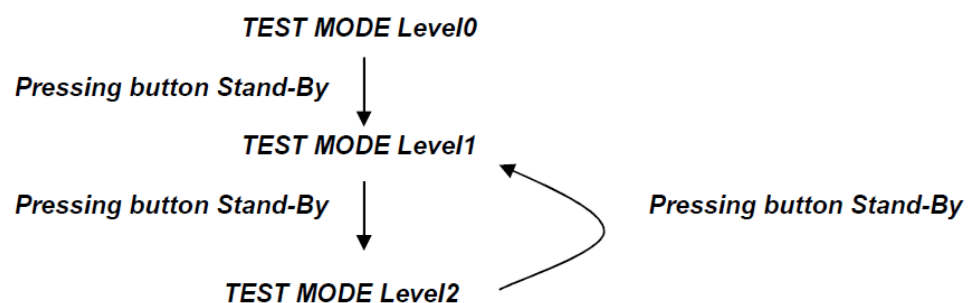

At the start up all loads are turned off. The software allow to have multiple loads active at the same time.

Test mode

Level 0 (Start test mode)

Start condition: NO BU, NO drag drawer, Door open, No Water	LED INDICATION
	L1 and L2 Blink Alternately

Level 1 (Keys, Buzzer, Leds)

Start condition: NO BU, NO drag drawer, Door open, No Water	LED INDICATION
	All Leds OFF

Sequence of actions by user	Reaction of the appliance			
	PASS	FAIL	Cause of failure	Solution
Press button B2	L1(O) ON, It's possible to hear the feedback sound.	L1 OFF	L1 damaged	Change UI board
		L1(IO) ON	L1 wrong color	Change UI board
		Other Lx toggle	Short circuit in Leds or Buttons	Change UI board
		It's not possible to hear the sound	The drive of the Buzzer or the Buzzer in the Main is damaged	Change Main Board
		The sound is persistent	The drive of the Buzzer or the Buzzer in the Main is damaged	Change Main Board
Press button B2	L1(O) & L2(O) ON	L2 OFF	L2 damaged	Change UI board
		L2(IO) ON	L2 wrong color	Change UI board
		Other Lx toggle	Short circuit in Leds or Buttons	Change UI board
Press button B2 (optional)	L1 & L2 OFF			
Press button B4	L5(O) ON	L5 OFF	L5 damaged	Change UI board
		L5(IO) ON	L5 wrong color	Change UI board
		Other Lx toggle	Short circuit in Leds or Buttons	Change UI board
Press button B4	L5(O) & L6(O) ON	L6 OFF	L6 damaged	Change UI board
		L6(IO) ON	L6 wrong color	Change UI board
		Other Lx toggle	Short circuit in Leds or Buttons	Change UI board
Press button B4 (optional)	L5 & L6 OFF			
Press button B6 (only 3B&3C)	L8(O) ON	L8 OFF	L8 damaged	Change UI board
		L8(IO) ON	L8 wrong color	Change UI board
		Other Lx toggle	Short circuit in Leds or Buttons	Change UI board
Press button B6 (only 3B&3C)	L8(O) & L9(O) ON	L9 OFF	L9 damaged	Change UI board
		L9(IO) ON	L9 wrong color	Change UI board
		Other Lx toggle	Short circuit in Leds or Buttons	Change UI board
Press button B6 (optional)	L8 & L9 OFF			
Press button B3	L3(O) ON	L3 OFF	L3 damaged	Change UI board
		L3(IO) ON	L3 wrong color	Change UI board
		Other Lx toggle	Short circuit in Leds or Buttons	Change UI board

Test mode

Press button B3 (only 2A)	L3(O) & L4(O) ON	L4 OFF	L4 damaged	Change UI boad
		L4(!O) ON	L4 wrong color	Change UI boad
		Other Lx toggle	Short circuit in Leds or Buttons	Change UI boad
Press button B3 (optional)	L3 & L4 OFF			
Press button B5	L7(O) ON	L7 OFF	L7 damaged	Change UI boad
		L7(!O) ON	L7 wrong color	Change UI boad
		Other Lx toggle	Short circuit in Leds or Buttons	Change UI boad
Press button B5 (optional)	L7 OFF			
Press button B7 (only 3B&3C)	L10(O) ON	L10 OFF	L10 damaged	Change UI boad
		L10(!O) ON	L10 wrong color	Change UI boad
		Other Lx toggle	Short circuit in Leds or Buttons	Change UI boad
Press button B7 (optional)	L10 OFF			
Press button B8	L11(O) ON	L11 OFF	L11 damaged	Change UI boad
		L11(!O) ON	L11 wrong color	Change UI boad
		Other Lx toggle	Short circuit in Leds or Buttons	Change UI boad
Press button B8	L11(O) & L12(O) ON	L12 OFF	L12 damaged	Change UI boad
		L12(!O) ON	L12 wrong color	Change UI boad
		Other Lx toggle	Short circuit in Leds or Buttons	Change UI boad
Press button B8	L11(O) & L12(O) & L13(O) ON	L13 OFF	L13 damaged	Change UI boad
		L13(!O) ON	L13 wrong color	Change UI boad
		Other Lx toggle	Short circuit in Leds or Buttons	Change UI boad
Press button B8	L11(O) & L12(O) & L13(O) & L14(O) ON	L14 OFF	L14 damaged	Change UI boad
		L14(!O) ON	L14 wrong color	Change UI boad
		Other Lx toggle	Short circuit in Leds or Buttons	Change UI boad
Press button B8 (optional)	L11 & L12 & L13 & L14 OFF			
Press button B9	L15(O) ON	L15 OFF	L15 damaged	Change UI boad
		L15(!O) ON	L15 wrong color	Change UI boad
		Other Lx toggle	Short circuit in Leds or Buttons	Change UI boad
Press button B9	L15(O) & L16(O) ON	L16 OFF	L16 damaged	Change UI boad
		L16(!O) ON	L16 wrong color	Change UI boad
		Other Lx toggle	Short circuit in Leds or Buttons	Change UI boad
Press button B9	L15(O) & L16(O) & L17(O) ON	L17 OFF	L17 damaged	Change UI boad
		L17(!O) ON	L17 wrong color	Change UI boad
		Other Lx toggle	Short circuit in Leds or Buttons	Change UI boad
Press button B9 (optional)	L15 & L16 & L17 OFF			
Press button B10 (only 3B&3C)	L21(O) ON	L21 OFF	L21 damaged	Change UI boad
		L21(!O) ON	L21 wrong color	Change UI boad
		Other Lx toggle	Short circuit in Leds or Buttons	Change UI boad
Press button B10 (only 3B&3C)	L21(O) & L22(O) ON	L22 OFF	L22 damaged	Change UI boad
		L22(!O) ON	L22 wrong color	Change UI boad
		Other Lx toggle	Short circuit in Leds or Buttons	Change UI boad

Test mode

Press button B10 (only 3B&3C)	L21(O) & L22(O) & L23(O) ON	L23 OFF	L23 damaged	Change UI board
		L23(!O) ON	L23 wrong color	Change UI board
		Other Lx toggle	Short circuit in Leds or Buttons	Change UI board
Press button B10 (optional) (only 3B&3C)	L21 & L22 & L23 OFF			
Press button B11	L18(O) ON	L18 OFF	L18 damaged	Change UI board
		L18(!W) ON	L18 wrong color	Change UI board
		Other Lx toggle	Short circuit in Leds or Buttons	Change UI board
Press button B11	L18(O) OFF & L19(B) ON	L19 OFF	L19 damaged	Change UI board
		L19(!B) ON	L19 wrong color	Change UI board
		Other Lx toggle	Short circuit in Leds or Buttons	Change UI board
Press button B11 (optional)	L18 & L19 OFF			
Press button B12	L20(O) ON	L20 OFF	L20 damaged	Change UI board
		L20(!O) ON	L20 wrong color	Change UI board
		Other Lx toggle	Short circuit in Leds or Buttons	Change UI board
Press button B12 (optional)	L20 OFF			
Press button B13	L27(O) ON	L27 OFF	L27 damaged	Change UI board
		L27(!O) ON	L27 wrong color	Change UI board
		Other Lx toggle	Short circuit in Leds or Buttons	Change UI board
Press button B13 (optional)	L27 OFF			

Finish condition: NO BU, NO drag drawer, Door open, No Water	LED INDICATION
	All Leds OFF (in case that also optional was done)

Legenda

Text	Group	Description
Press button Bx	Sequence of actions by user	Press the button Bx. Valid in all models
Press button Bx (only X&Y)	Sequence of actions by user	Press the button Bx. Valid only in the model X & Y
Press button Bx (optional)	Sequence of actions by user	Press the button Bx. Not requested but if the operator will do it the machine will react in the described way.
Lx (y) ON	Reaction of the appliance	The led Lx switches On with the color y. Color code: y=W -> color White y=R -> color Red y=O -> color Orange
Lx OFF	Reaction of the appliance	The led Lx switches Off.
Lx (!y) ON	Reaction of the appliance	The led Lx switches On with a different color from the expected y. FAILURE MODE.

Test mode

Level 2 (Loads and sensor)

Start condition: NO BU, NO drag drawer, Door open, No Water	LED INDICATION L24 & L26 ON
--	--------------------------------

Sequence of actions by user	Reaction of the appliance			
	PASS	FAIL	Cause of failure	Solution
Check the start condition	L24(R) & L25(R) ON	L24(!R) ON	L24 wrong color	Change UI board
		L25(!R) ON	L25 wrong color	Change UI board
		L24 OFF	L24 damaged	Change UI board
			Water level sensor damaged (short circuit)	Change Water level sensor
			Connector JP14 in Main damaged (short circuit)	Change Main board
			uP U2 in Main damaged (short circuit in Pin9)	Change Main board
		L25 OFF	L25 damaged	Change UI board
			The Microswitch is not well placed	Check assembly of microswitch
			Microswitch damaged (short circuit)	Change microswitch
			Connector JP3 in Main damaged (short circuit)	Change Main board
		uP U2 in Main damaged (short circuit in Pin26)	Change Main board	
Insert BrewUnit & Close Door (No Dump Box)	No changes	L25 OFF	Assembly issue of the microswitch or mechanical lever.	Check microswitch position and mechanical lever.
Insert a full water tank	L24(R) OFF	L24 remain ON	The floater in the Water tank is blocked or missing	Check the floater in the Water Tank
			Water level sensor not in position	Change the position of Water level sensor
			Water level sensor damaged (open circuit)	Change Water level sensor
			Wiring of the water level sensor not connected	Check the wiring
			Wiring of the water level sensor damaged (open)	Change the wiring
			uP U2 in Main damaged (open circuit in Pin9)	Change Main Board
Insert Dreg drawer and drip	L25(R) OFF	L25 remain ON	The Microswitch is	Check assembly of

Test mode

tray			not well placed	microswitch
			Microswitch damaged (open circuit)	Change microswitch
			Wiring of the microswitch not connected	Check the wiring
			Wiring of the microswitch damaged (open)	Change the wiring
			uP U2 in Main damaged (open circuit in Pin26)	Change Main board
Brew Unit				
Press and release B2 to move BU to work. N.B: * If the BU is already moving to home then stop the movement and change the direction into work. * If the BU is already moving to work then stop the movement.	L1(O) ON while BU is moving.	BU not move	Wiring of the BU motor not connected	Check the wiring
			Wiring of the BU motor damaged (open)	Change Main Board
			Motor of BU damaged	Change the BU motor
			The drive of the motor in the Main is damaged	Change Main Board
			BU blocked	Check the BU
			Gears or motor not well assembled	Check the assembly of the gear and motor
		BU move to Home	Wiring of BU motor are inverted	Check the Motor BU wiring
		L26 ON	The absorbed current exceed the limit (200ma).	Check the assembly of the gear and motor, check the BU
	L1(O) Blink when BU has reached work position, BU OFF	L1 OFF & L26 Blink and BU OFF. Work not reached	The BU Microswitch is not well placed	Check assembly of BU microswitch
			BU Microswitch damaged (open circuit)	Change BU microswitch
			Wiring of the BU microswitch not connected	Check the wiring
			Wiring of the BU microswitch damaged (open)	Change the wiring
uP U2 in Main damaged (open circuit in Pin26)			Change Main board	
Press and release B3 to move BU to home. N.B: * If the BU is already moving to work then stop the movement and change the direction into home.	L3(O) ON while BU is moving.	BU not move	Wiring of the BU motor not connected	Check the wiring
			Wiring of the BU motor damaged (open)	Change the motor BU wiring
			Motor of BU	Change the BU motor

Test mode

* If the BU is already moving to home then stop the movement.			damaged		
			The drive of the motor in the Main is damaged	Change Main Board	
			BU blocked	Check the BU	
			Gears or motor not well assembled	Check the assembly of the gear and motor	
		BU move to Work	Wiring of BU motor are inverted	Check the Motor BU wiring	
		L26 ON	The absorbed current exceed the limit.	Check the assembly of the gear and motor, check the BU	
	L3(O) Blink when BU has reached home position, BU OFF		L3 OFF & L26 Blink and BU OFF. Home not reached	The BU Microswitch is not well placed	Check assembly of BU microswitch
				BU Microswitch damaged (open circuit)	Change BU microswitch
				Wiring of the BU microswitch not connected	Check the wiring
				Wiring of the BU microswitch damaged (open)	Change the wiring
uP U2 in Main damaged (open circuit in Pin26)				Change Main board	
EV1					
Press and release B5 to toggle the EV. If it was closed, then will be open.	L7(O) OFF -> ON. It's possible to hear the "click".	The "click" is no audible. The EV remain closed	Wiring of the EV1 not connected	Check the wiring	
			Wiring of the EV1 damaged (open)	Change Main Board	
			EV1 damaged	Change the EV1	
			The drive of the EV1 in the Main is damaged	Change Main Board	
Press and release B5 to toggle the EV. If it was open, then will be closed.	L7(O) ON -> OFF. It's possible to hear the "click".	The "click" is no audible. The EV remain open	EV1 damaged	Change the EV1	
			The drive of the motor in the Main is damaged	Change Main Board	
EV2					
Press and release B12 to toggle the EV. If it was closed, then will be open. ONLY FOR LATTEGO	L20(O) OFF -> ON. It's possible to hear the "click".	The "click" is no audible. The EV remain closed	Wiring of the EV2 not connected	Check the wiring	
			Wiring of the EV2 damaged (open)	Change Main Board	
			EV2 damaged	Change the EV2	
			The drive of the EV2 in the Main is damaged	Change Main Board	
Press and release B12 to toggle the EV. If it was open, then will be closed.	L20(O) ON -> OFF. It's possible to hear the "click".	The "click" is no audible. The EV remain open	EV2 damaged	Change the EV2	
Pump and Flowmeter					

Test mode

<p>Press and release B4 to switch on the Pump (100 impulses). With the EV open the water goes out from the HotWater spout. With the EV closed the water goes out from the Coffee spout.</p>	L5(O) ON & L19(B) BLINK followig the impulses of the flowmeter	<p>L5 ON & L19 remain OFF, Pump ON and after 5sec. L5 OFF & L26 ON, Pump OFF.</p>	Wiring of the Flowmeter not connected	Check the wiring	
			Wiring of the Flowmeter damaged (open)	Change the wiring	
			Flowmeter damaged	Change the Flowmeter	
			Connector JP20 in Main damaged (short circuit)	Change Main Board	
		<p>L5 ON & L19 remain OFF, Pump OFF, and after 5sec. L5 OFF & L26 ON , Pump OFF.</p>		Wiring of the PUMP not connected	Check the wiring
				Wiring of the PUMP damaged (open)	Change Main Board
				PUMP damaged	Change the PUMP
				The drive of the Pump in the Main is damaged	Change Main Board
ThermoBlock and NTC					
<p>Press and release B8 to toggle the ThermoBlock. Check the absorbed current. In this case we suppose that was OFF, then will be ON 100%.</p>	L11(O) OFF->ON	L26 ON	Wiring of the NTC not connected	Check the wiring	
			Wiring of the NTC damaged (open)	Change the wiring	
			NTC damaged	Change the wiring	
			Connector JP15 in Main damaged (short circuit)	Change Main Board	
			uP U2 in Main damaged (short circuit in Pin24)	Change Main Board	
	<p>The current is out of range</p>		TB damaged	Change the TB	
			The drive of the TB in the Main is damaged	Change Main Board	
	<p>L11(O) OFF & L26(R) Blink</p>		The TB has reached the max temperature.	Brew water to reduce the temperature. And repeat the test.	
			<p>The current is very low <0,5A.</p>	Wiring of the TB not connected	Check the wiring
				TCO open	Change theTCOs
				Wiring of the TB damaged (open)	Change the wiring
				TB damaged	Change the TB
	The drive of the TB in the Main is damaged	Change Main Board			
	<p>Press and release B8 to toggle the ThermoBlock. Check the absorbed current < 0,5A. In this case we suppose that was ON, then</p>	L11(O) ON->OFF	<p>The current is still present>0,5A.</p>	The drive of the TB in the Main is damaged	Change Main Board

Test mode

will be OFF.				
Grinder				
Press and release B9 to toggle the Grinder. If it was OFF, then will be ON and will move in clockwise direction.	L15(O) OFF->ON	L15 OFF & L26 ON	Wiring of the Grinder not connected	Check the wiring
			Wiring of the Grinder damaged (open)	Change the wiring
			Grinder damaged	Change the Grinder
			Grinder blocked	Change the Grinder
		The drive of the Grinder in the Main is damaged	Change Main Board	
		The rotation direction is wrong: anti-clockwise	Wirings of Grinder are inverted	Check the Grinder wiring
Press and release B9 to toggle the Grinder. If it was ON, then will be OFF.	L15(O) ON->OFF	The grinder is still rotating.	The drive of the Grinder in the Main is damaged	Change Main Board

N.B:

If the Dreg drawer is not inserted or the Service door is not closed the following loads cannot be tested:

1. BU
2. EV

Functions/features explanation

Steam out

The machine enters in Steam-Out mode by pressing in sequence B4, B2, B5, B3 (drawing like an “S”) in the first two seconds after inserting the plug into the socket. (Please make sure to avoid any serial connection on Main board white connector).

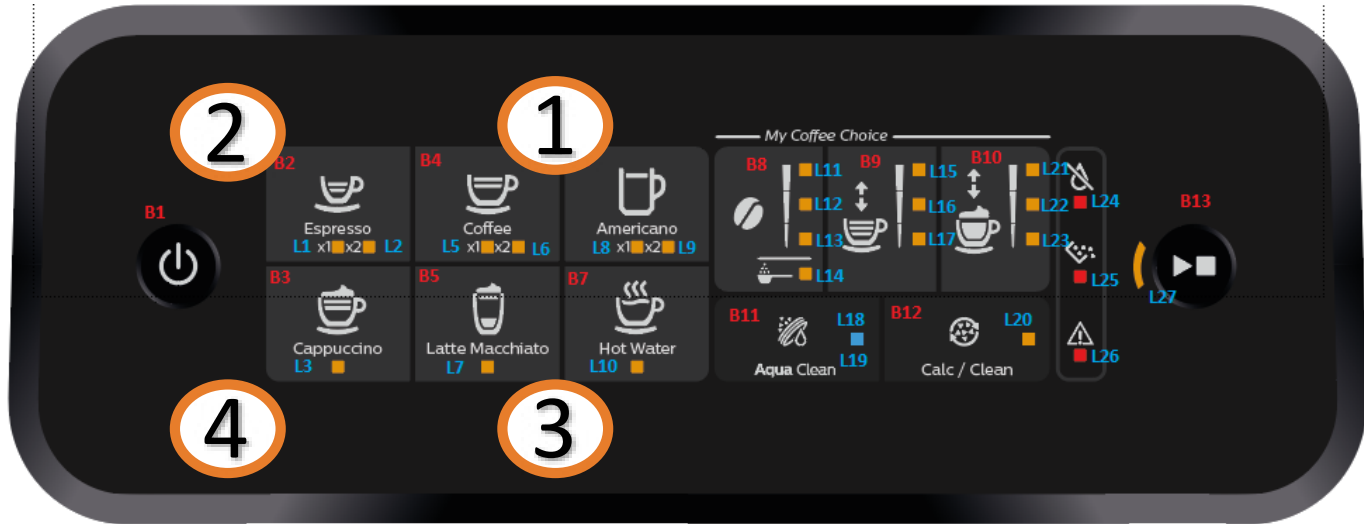

Once entered the machine checks the following conditions:

The Ntc sensor must work correctly; if there is a failure on NTC (Ntc disconnected or in short circuit) the operation cannot be performed and the L26 will blink (turn off the machine and repair before do Steam-out operation).

The DREGDRAWER must be in place and the DOOR must be closed; if someone is not in place the operation cannot be performed and the L25 will blink. To start again the operation insert drag drawer and close service door.

If these 2 conditions are respected the machine will start automatically the Steam Out process showing L18 and L20 flashing in series.

If, during the Steam Out, the Door is opened or drag drawer is removed L25 will be switched on. To start again the operation insert drag drawer and close service door.

At the end of the procedure L25 and L26 turns on.

When the Steam-Out is complete the following parameters are reset to their default values:

Parameters	Default values	Descriptions
Qty Espresso Custom (ml)	See specifications	Length “Espresso” product
Qty Coffee Custom (ml)	See specifications	Length “Coffee” product
Qty Hot Water Custom (ml)	See specifications	Length “HotWater” product
Qty Espresso Lungo Custom (ml)	See specifications	Length “Espresso Lungo” product
Qty Americano Custom Coffee (ml)	See specifications	Length “Americano” product, coffee
Qty Americano Custom Water (ml)	See specifications	Length “Americano” product, water
Qty Capuccino Custom Coffee (ml)	See specifications	Length “Cappuccino” product, coffee
Qty Capuccino Custom Milk (ml)	See specifications	Length “Cappuccino” product, milk
Qty Latte Macchiato Custom Coffee (ml)	See specifications	Length “Latte Macchiato” product, coffee
Qty Latte Macchiato Custom Milk (ml)	See specifications	Length “Latte Macchiato” product, milk

Philips EP Series

Functions/features explanation

Parameters	Default values	Descriptions
Temperature setting	Medium	Temperature setting
Coffee Grounds	Reset counter	Number of grounds in dregs drawer
Aroma (all drinks)	Medium	Aroma for all drinks
Pre selected quantity (coffee, water and milk)	Medium	Restore the default length (medium)
Error log [i]	0	Array Error saved in machine resetted
BU Unloaded Current Array[i]	150	Array of last 4 brew unit effort during rinsing cycle (in milliamperes). → Autozero for new autodose system
Gr_time_aroma [Light]	3000	Grinding time for aroma 1 (ms)
Gr_time_aroma [Medium]	3500	Grinding time for aroma 2 (ms)
Gr_time_aroma [Strong]	4000	Grinding time for aroma 3 (ms)
Filter_autonomy	0	Autonomy of last Aqua clean filter actived
Filter_counter	0	Number of Aqua clean filter actived in aqua-clean chain
Filter_startup_qty	See requirement	Counter of water for enable first Aqua Clean filter; if expire, the machine need a descaling action to activate a new filter.

Coffee

Drinks	Low button (ml)	Medium button (ml)	High button (ml)	Volume adjustment (only at high button - ml)
Espresso	30	40	70	40-220
Coffee	100	120	200	120-220
Espresso lungo	60	80	180	80-220
Americano (water)	40 (50)	40 (110)	40 (160)	40 (110-360)
Cappuccino (milk)	30 (90)	40 (120)	60 (200)	40-220 (120-340)
Latte macchiato (milk)	30 (120)	40 (200)	50 (340)	40-220 (200-340)
Hot water	60	150	360	150-360
Iced coffee	90	120	150	120-220

Functions/features explanation

Descaling

Please use Philips descaler only. Under no circumstances should you use a descaler based on sulfuric acid, hydrochloric acid, sulfamic or acetic acid (vinegar) as this may damage the water circuit in your machine and not dissolve the limescale properly. Not using the Philips descaler will void your warranty. Failure to descale the appliance will also void your warranty.

When the Calc / Clean light starts to flash slowly, you need to descale the machine.

1. If attached remove LatteGo or milk frother.
2. Remove the drip tray and the coffee grounds container, empty them and put them back into place.
3. Remove the water tank and empty it. Then remove the AquaClean water filter.
4. Pour the whole bottle of Philips descaler in the water tank and then fill it with water up to the Calc/Clean indication. Then place it back into the machine.
5. Place a large container (1.5 l) under the coffee dispensing spout and the water spout.
6. Press the Calc / Clean icon for 3 sec. and then press the start/stop button.
7. The first phase of the descaling procedure starts. The descaling procedure lasts approx. 30 minutes and consists of a descaling cycle and a rinsing cycle. During the descaling cycle the Calc / Clean light flashes to show that the descaling phase is in progress.
8. Let the machine dispense the descaling solution until the display reminds you that the water tank is empty.
9. Empty the water tank, rinse it and then refill it with fresh water up to the Calc / Clean indication.
10. Empty the container and place it back under the coffee dispensing spout and the water spout. Press the start/stop button again.
11. The second phase of the descaling cycle, the rinsing phase, starts and lasts 3 minutes. During this phase the lights on the control panel go on and off to show that the rinsing phase is in progress.
12. Wait until the machine stops dispensing water. The descaling procedure is finished when the machine stops dispensing water.
13. The machine will now heat up again. When the lights in the drink icons light up continuously, the machine is ready for use again.
14. Install and activate a new AquaClean water filter in the water tank
15. When the descaling procedure is finished, the AquaClean light flashes for a while to remind you to install a new AquaClean water filter.

What to do if the descaling procedure is interrupted

You can exit the descaling procedure by pressing the on/off button on the control panel. If the descaling procedure is interrupted before it is completely finished, do the following:

1. Empty and rinse the water tank thoroughly.
2. Fill the water tank with fresh water up to the Calc / Clean level indication and switch the machine back on. The machine will heat up and perform an automatic rinsing cycle.
3. Before brewing any drinks, perform a manual rinsing cycle. To perform a manual rinsing cycle, first dispense half a water tank of hot water by repeatedly tapping the hot water icon and then brew 2 cups of pre-ground coffee without adding ground coffee.

If the descaling procedure was not completed, the machine will require another descaling procedure as soon as possible.

Functions/features explanation

Temporary solutions

Cable tie for the pump

To make sure the pump won't move from its place. The pump will be assembled with a cable tie. In case a swap is needed, please follow these step to place it back:

1. Start inserting a cable tie (20cm x 1,2mm) in the empty space of the pump holder, then keeping both pull them inside:



2. In pictures 1 and 2 you can see the exactly position where to place the cable tie.
3. Don't close it too much: the leftover cable needs to be 5cm to guarantee the proper tightness (picture 3)

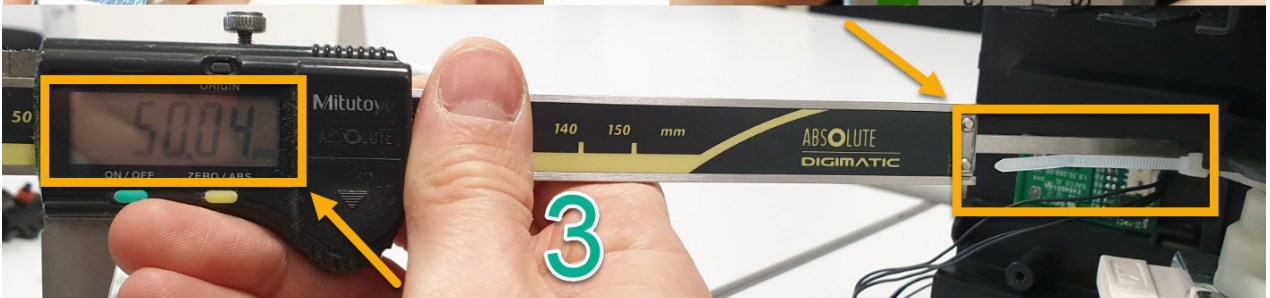
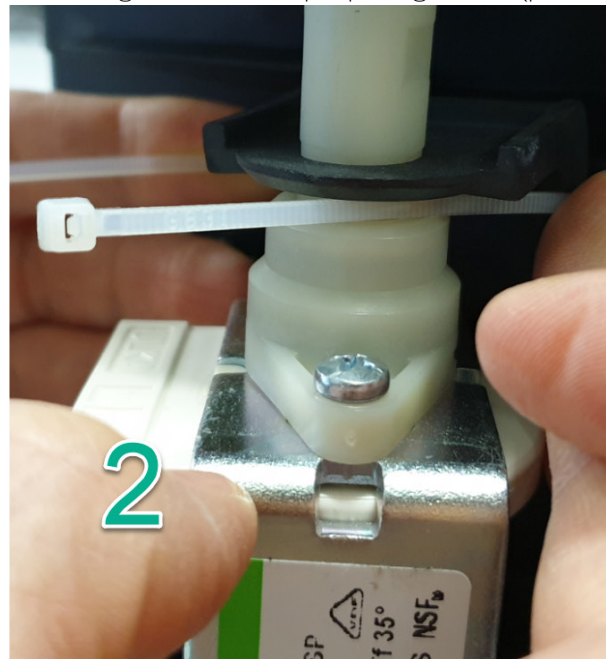
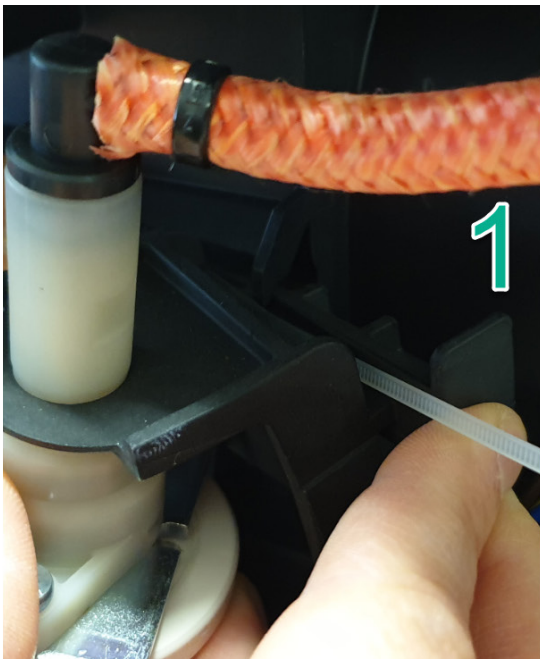

Functions/features explanation

Temporary solutions

Tape for service door

Before the shipment of the appliances, is required to apply 4 pcs of adhesive tape as shown in picture.

1. Do not cover the water sensor area (in red)
2. Do not leave any gap between the tape and the corner (green arrows)

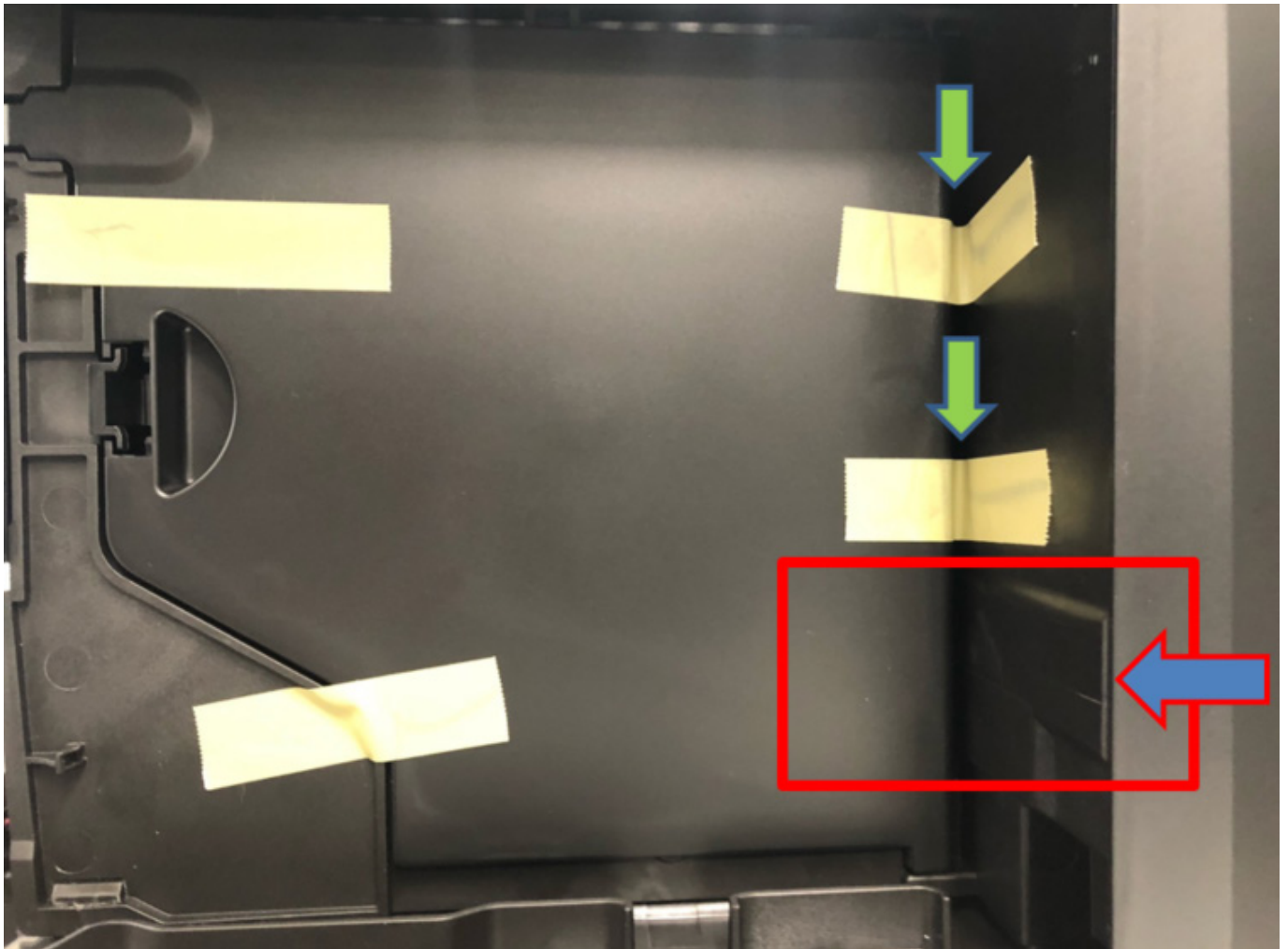

Functions/features explanation

Espresso Philips Service Center (EPSC)

EPSC is the Service tool to upload the software on the machine and run the diagnostic mode.

It can be downloaded from the following link: <https://www.epsc.versuni.com/ServiceCenterPortal>

The application can be used only in combination with the Saeco Programming Device:

Cod. **996530009845** “KIT PROGRAMMER SERKIT SSC2”.

A new cable **421946047151** “WIRING SERPROG OMN PROGRAMMER ASSY.” is required.

They can be ordered as spare parts.

All details related to the registration and operation are explained in the enclosed Quick start guide (QSG).

Espresso Philips Service Center– Quick Start Guide

Press the icon to view the document

To open the attached document is necessary to save the service manual on your PC.

The main Diagnostic Parameters description is available on the GDA_114331.



In order to connect the machine to the PC, we need to remove the back panel, which will expose the complete mainboard

REMEMBER: The board is working at 230V

Only for connected models: EP2520/10 and EP3546/70 in order to connect the machine to the PC, remove the wi-fi cable and connect the programmer cable. It's only possible to run the diagnostic read. The software update will be run via wi-fi.

Please take extra care before you start to open the machine or connect/disconnect the programmer cable, as till the USB programmer, high voltage is going through

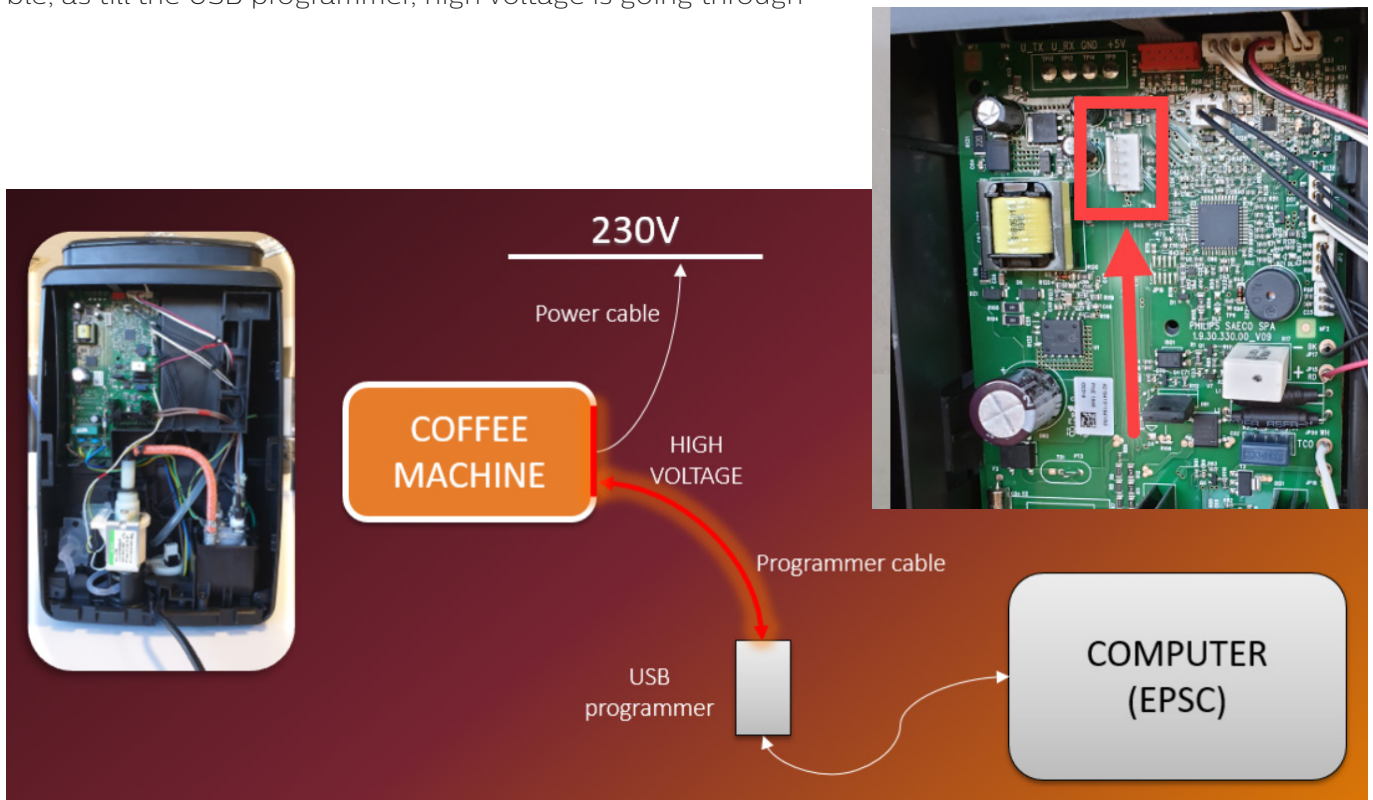

Functions/features explanation

Deactivate AquaClean filter reminder

If you would like to deactivate or turn off the AquaClean filter reminder on your Philips 1200/2200/3200 espresso machine, follow the steps below.

1. Switch OFF the machine
2. Press and hold the AquaClean button for 3 seconds until the AquaClean icon light is on and the start/stop button starts blinking
3. Press the start/stop button again to turn off the AquaClean icon light
4. Your AquaClean filter reminder is now deactivated

Note: Once deactivated, you will not receive any notification after you descale your machine. If you wish to use AquaClean filter in the future, can activate it again by pressing the AQ filter icon for 3 seconds

Deactivate the beeping sound of the buttons

It is possible to deactivate the beeping sound, please follow the instructions below:

1. Press the ON/OFF button to switch OFF the machine
2. Press and hold the Coffee icon (or Espresso Lungo icon for Philips EP3221 model) for 3 seconds
3. The x1 cup light of the Coffee icon is light up and START/STOP light starts to blink. This indicates that the sound setting is set to ON.
4. Press the Coffee icon again to switch the x1 cup light icon off. The sound setting is now set to off.
5. Press the start/stop button to save the setting
6. Press the ON/OFF button to switch the machine back ON.

Note: Deactivating the beeping sound is not possible for the on/off button and the start/stop button

Reset drinks settings to default setting

1. Switch OFF the machine
2. Press and hold the Espresso icon for 3 seconds
3. The screen will show the default settings on the aroma strength/pre-ground coffee icon, drink quantity icon, milk quantity icon (specific models only), coffee temperature icon (specific models only)
4. Start/stop button will start to pulse, indicating that the settings are ready to be restored
5. Press the start/stop button to confirm you want to restore to the default settings
6. Press the ON/OFF button to switch the ON again

Functions/features explanation

Repair Flow

Process step	Saeco no.	Action	
Intake	1	Visual inspection (transport damage) take care for pictures	
	2	Check Type/serialnumber	
	3	Log all available accessory, counter check with info from consumer	
Diagnosis	4	Check product for consumer complaint and main function (NFF contact consumer)	
	5	Run Diagnostic to get error codes and relevant set statistics (EPSC refer SDA_114585)	
	6	Opening machine	
Repair	7	Repairing the fault(s) encountered (view Symptom Cure)	
	8	Checking any modifications (view Symptom Cure, new software, etc.) Refer Annex tabs per family (if available)	
	9	Basic Functional test while the appliance is open (linked to consumer complaint or what you may have detected) <i>Make e 2 cups at the same time. Are the volumes equal</i> <i>Blow on the coffee. Does the crema come back together</i> <i>Is the crema colour correct (Hazelnut)</i> <i>Is the coffee temperature within spec refer SDA_97832</i> <i>Does the steam work</i> <i>Does the hot water work</i> <i>(if applicable)</i> <i>Does the cappuccinatore produce good froth</i>	
		10	check water circuit for any leakage, such as Oetiker clamps, boiler and valve connection and hoses
		11	Check mechanism for good movement and unexpected noise
		12	Assembly
		13	Do cabinet parts fit well together
		14	Check for damages
		15	Will the set switch on
		16	Do the accessories match with the intake
		17	Check the product for the consumer complaint
	Inspection		- visual
		- Power check	
		- Accessories	
		- Consumer complaint	
Quick Functional test	18	Make 2 cups at the same time. Are the volumes equal	
	19	Is the sound normal ?	
Leakage	20	Did the product leak during the testing	
Steam Out		Steam out before shipping out, if temperature is below 0° to prevent any damaged due to frozen water. No need for those families Minuto Family (all platform); Incanto Family New.; Pico Baristo; Gran Baristo; Intelia V2; Philips 2000 – 2100; Incanto Executive; Xelsis-New; Moltio Family (all Platform) Please also check for GDA_113455	
	21		
Reset Error code		New devices like Xelsis-New have the possibility to reset the error code, once captured it need to be reset to see if it appear afterwards again	
	22		
Claim Administration		Provide precise IRIS code, according dedicated code table for Garment Care products. The location code from the part you have worked on MUST be completed always with the part reference from exploded view !	
	23	Primary fault and corresponding IRIS code should be claimed first.	
Cleaning	25	Clean water reservoir, bean reservoir, brew chamber and conveyor	
	26	Clean and dry brew unit, coffee bin and drip tray	
	27	External cleaning (housing surface)	
Safety check	28	Earth leakage, Isolation test, resistor of earth wire grounding, as requested in certain country's (VDE, ISO) or H-POT TEST	
	29	Check the mains cord for damages	
Packing	30	Packing	
	31	Check completeness (accessories) according income log refer #3	
	32	Neatly pack the product	
Documentation	33	Info for Consumer by packed ? e.g. service brochure, FAQ, NFF letter, s/c etc....	
	34	Descaling instruction with changed procedure (S/C) if available	
Repair report	35	Is there an answer to ALL consumer questions/complaints (see complaint)	
	36	add set statistic and give, if needed clear instruction towards consumer	
	37	Is it indicated which documents are added	
	38	Are there tips how to prevent issues	

Version history

28/03/19 Version 1.0 : Initial release.

04/06/21 Version 1.1 : On page 06: Under General Information, added pictures of front panel for flash WI-Fi models.

On page 14: Under Technical Information, added How to check connectivity board (Only for WI-Fi models).

17/05/22 Version 1.2 : On page 06: Under General Information, added pictures of front panel for Latte Go Iced coffee Version.

On page 08: Under Technical Information, added Iced coffee specifications.

On page 09: Under Technical Information, added Specification for the measurement of the coffee products temperature for Iced coffee.

14/06/22 Version 1.3 : On page 04: Under General Information, added picture for 800 series model.

On page 05: Under General Information, added picture of front panel for 800 series model.

On page 07: Under Technical Information, added specification of Lattego EV.

07/07/22 Version 1.4 : On page 45: Under Functions/features explanation, added information on how to connect the programmer cable on the connected models EP2520/10 and EP3546/70.

13/04/23 Version 1.5 : On page 11: Under Technical information, in Specification for the measurement of the Milk products temperature added information about the replacement of the Pannarello.

On page 45: Under Functions/features explanation, updated EPSC link to new server environment and QSG guide.



www.philips.com